



Islamic University of Gaza  
Faculty of Engineering  
Electrical Engineering Department

## **A New Approach of Robust Internal Model Control for Nonlinear Pendulum System**

By  
Walid R. Issa

Supervisor  
Dr. Basil Hamed

This thesis is submitted in Partial Fulfillment of the  
Requirements for the Degree of Master of Science in  
Electrical Engineering  
Islamic University of Gaza, Palestine

م 2011 - 1432 هـ



*TO MY PARENTS, BROTHERS, SISTER, WIFE, AND LOVELY KID OSSAMA*

## ACKNOWLEDGMENTS

I would like to express my deep appreciation to my thesis advisor Dr. Basil Hamed for providing his advice, encouragement and his excellent guidance during research. I would like to thank the other committee members Dr. Hatem Al-Aydi and Dr. Iyad Abu Hadrous for providing their valuable suggestions. In addition, my thanks go to my friends and colleagues for their advices and supports.

There are no words that describe how grateful I am to my parents for raising me and for their support and encouragement through years. My deepest thanks go to my wife and my child Ossama for their patience and understanding during my busy schedule.

## ABSTRACT

The internal model control (IMC) philosophy relies on the internal model principle, which states that control can be achieved only if the control system encapsulates, either implicitly or explicitly, some representation of the process to be controlled. In particular, if the control scheme is developed based on an exact model of the process, then perfect control is theoretically possible.

A new approach of control design of internal model controller is proposed in this thesis. The proposed design method focuses on modifying the old general structure of IMC and develops a new model structure while saving the same general concept of using the invertible version of the system in the controller design. The new approach combines the IMC structure and the traditional structure of a control problem and this demonstrates an excellent performance and behavior against different disturbance inputs and model uncertainty presented in model parameter mismatch. Beside that a smith predictor is added to promote the design to compensate the delayed time systems. Also a proposed stabilizer has mentioned to deal with unstable systems.

The research browses the pendulum system and gets its transfer function to be the base of the design, which examines our proposed controller.

Matlab/simulink is used to simulate the procedures and validate their performance. The results approved the robustness of the new method and got graded responses when compared with others. Furthermore, a comparison between the IMC and new modified IMC was conducted and shows that the new IMC is superior to old structure in terms of time delay compensation and response specifications.

## ملخص البحث

ان فلسفة التحكم النمودجي الداخلي يعتمد على مبدأ النمودج الداخلي والذي ينص على انه يمكن تحقيق التحكم اذا تضمن نظام التحكم بطريقة ضمنية او صراحة بعض مكونات العملية المراد التحكم بها. خاصة اذا تم تطوير خطة التحكم بناء على تمثيل كامل للعملية فانه نظريا يتم تحقيق التحكم التام.

في هذا البحث تم اقتراح طريقة جديدة لهذا النوع من التحكم بحيث تم التركيز على كيفية تغيير بناء هذا التحكم واستبداله ببناء جديد مع حفظ المبدأ الخاص به من ناحية استخدام معكوس النظام في تصميم المتحكم. الطريقة الجديدة تربط البناء القديم لمشاكل التحكم والبناء التقليدي لنظام التحكم النمودجي الداخلي واخراج بناء جديد.بالاضافة الى انه تم التعامل مع المتوقع سميث ليتم معالجة الانظمة ذات التأخير الزمني بجانب التعامل مع الانظمة غير المستقرة بوضع متحكم استقرار.

لقد استعرض هذا البحث نظام البندول لاستخدام دالة النقل الخاص به كاختبار للتحكم المقترح وبالإضافة الى اقتراح طريقة جديدة لطريقة التصميم.

تم استخدام برنامج الماتلاب لعمل محاكاة والتحقق من صحة الاجراءات المقترحة.وأثبتت النتائج منانة النظام الجديد بالمقارنة مع غيره بالاضافة الى انه تم مقارنة هذا النظام مع النظام القديم وتم استنتاج فعالية الطريقة الجديدة.

# TABLE OF CONTENTS

<b>CHAPTER 1</b>	<b>INTRODUCTION.....</b>	<b>1</b>
1.1.	INTRODUCTION.....	1
1.2.	MOTIVATION.....	2
1.3.	OBJECTIVES.....	2
1.4.	CONTRIBUTION.....	3
1.5.	LITERATURE REVIEW.....	3
1.6.	RESEARCH OUTLINE.....	4
<b>CHAPTER 2</b>	<b>INTERNAL MODEL CONTROL.....</b>	<b>5</b>
2.1.	INTRODUCTION.....	5
2.2.	IMC SYSTEM THEORY.....	7
2.3.	REQUIREMENTS FOR PHYSICAL REALIZABILITY ON THE IMC CONTROLLER.....	13
2.4.	SENSITIVITY FUNCTION.....	13
2.4.1.	<i>Overview</i> .....	13
2.4.2.	<i>Sensitivity Function</i> .....	14
2.4.3.	<i>Complementary Sensitivity Function</i> .....	15
2.4.4.	<i>Effects of measurement noise</i> .....	16
2.4.5.	<i>The trade-off between robustness and performance</i> .....	16
2.5.	INTERNAL MODEL CONTROL DESIGN PROCEDURE.....	17
2.6.	IMC FOR SYSTEMS WITH TIME DELAY.....	19
2.6.1.	<i>Introduction</i> .....	19
2.6.2.	<i>Smith Predictor</i> .....	21
2.7.	ROBUSTNESS OF IMC.....	24
2.8.	IMC FOR UNSTABLE SYSTEMS.....	25
<b>CHAPTER 3</b>	<b>MODIFIED INTERNAL MODEL CONTROL.....</b>	<b>27</b>
3.1.	INTRODUCTION.....	27
3.2.	MODIFIED IMC THEORY.....	27
3.3.	NUMERICAL EXAMPLE.....	29
3.4.	ROBUSTNESS OF MODIFIED IMC.....	31
3.5.	MODIFIED IMC FOR TIME DELAYED SYSTEMS.....	31
3.5.1.	<i>Introduction</i> .....	31
3.5.2.	<i>Numerical Example</i> .....	33
3.6.	MODIFIED IMC FOR UNSTABLE SYSTEMS.....	35
3.7.	SUMMARY.....	36
<b>CHAPTER 4</b>	<b>SIMULATION AND RESULTS.....</b>	<b>38</b>
4.1.	INTRODUCTION.....	38
4.2.	TWO MODES: SWINGING CRANE AND INVERTED PENDULUM.....	39
4.3.	CALCULATION AND INSTABILITY OF $\gamma$ FOR INVERTED PENDULUM.....	40
4.4.	DYNAMIC MODEL OF THE PENDULUM.....	40
4.5.	IMPULSE DISTURBANCE INPUT.....	41
4.6.	STEP DISTURBANCE INPUT.....	45
4.7.	BAND LIMITED WHITE NOISE DISTURBANCE AT THE PLANT OUTPUT.....	46
4.8.	SYSTEMS WITH A PLANT/MODEL MISMATCH.....	48
4.9.	SYSTEM WITH TIME DELAY.....	50
4.10.	COMPARISON WITH PREVIOUS WORK.....	51
<b>CHAPTER 5</b>	<b>CONCLUSION.....</b>	<b>55</b>
	REFERENCES.....	56

## LIST OF FIGURES

Figure (1.1):	Block Diagram of IMC .....	1
Figure (2.1):	Schematic Representation of the Internal Model Control Structure .....	5
Figure (2.2):	Application of IMC .....	7
Figure (2.3):	Evolution of the IMC structure: (A) Open loop (feedforward) system (B) Feedback system (C) IMC without disturbance input (D) IMC with disturbance input (E) Final structure of IMC with disturbance input .....	9
Figure (2.4):	Schematic of conventional feedback control loop .....	14
Figure (2.5):	Typical time delay system and feedback from Y .....	22
Figure (2.6):	Typical time delay system and feedback from B .....	23
Figure (2.7):	Preliminary form of the Smith Predictor .....	23
Figure (2.8):	Complete form of the Smith Predictor .....	23
Figure (2.9):	Rearrangement of smith predictor control scheme .....	23
Figure (2.10):	Stabilizing unstable system .....	25
Figure (2.11):	Modified IMC scheme .....	26
Figure (3.1):	Modified IMC structure .....	27
Figure (3.2):	Controller Closed Loop System .....	28
Figure (3.3):	$G_{sc}(s)$ Closed Loop .....	29
Figure (3.4):	$G_{sc}(s)$ Closed Loop response .....	30
Figure (3.5):	Overall closed Loop system .....	30
Figure (3.6):	Overall closed Loop system response .....	30
Figure (3.7):	The system with time delay .....	32
Figure (3.8):	The Impulse Response for $t = 0.3$ sec .....	32
Figure (3.9):	The Impulse Response for $t = 1$ sec .....	33
Figure (3.10):	Upper with smith predictor, Lower without smith predictor .....	33
Figure (3.11):	Results of the systems, dotted without SP, solid with SP .....	34
Figure (3.12):	The system of DC motor with smith predictor .....	34
Figure (3.13):	Result of DC motor system with smith predictor .....	34
Figure (3.14):	Modified IMC for Unstable systems .....	36
Figure (4.1):	Pendulum System .....	38
Figure (4.2):	Determination of Mass Position .....	39
Figure (4.3):	Block Diagram of the system with impulse disturbance input .....	42
Figure (4.4):	Impulse disturbance input response .....	43
Figure (4.5):	The closed loop response of $G_{sc}(s)$ .....	43
Figure (4.6):	The block diagram of the modified IMC .....	44
Figure (4.7):	The response of modified IMC .....	44
Figure (4.8):	IMC system with step disturbance input .....	45
Figure (4.9):	Step disturbance input response at $t=1$ sec .....	45
Figure (4.10):	Modified IMC with step disturbance input .....	46
Figure (4.11):	Step disturbance input response of modified IMC at $t=1$ sec .....	46
Figure (4.12):	IMC system with white noise disturbance input .....	47
Figure (4.13):	Band limited white noise disturbance .....	47
Figure (4.14):	Response of IMC system to WN disturbance input .....	47
Figure (4.15):	Modified IMC with to noise disturbance input .....	48
Figure (4.16):	Response of modified IMC system with WN disturbance input .....	48
Figure (4.17):	A plant/model mismatch of IMC system .....	49
Figure (4.18):	A plant/model mismatch of modified IMC system .....	49
Figure (4.19):	Response of IMC due to plant/model mismatch .....	50



Figure (4.20):	Response of modified IMC due to plant/model mismatch .....	50
Figure (4.21):	IMC structure with time delay mismatch .....	51
Figure (4.22):	Modified IMC structure with time delay .....	51
Figure (4.23):	Response of IMC with a mismatch time-delayed system.....	52
Figure (4.24):	Response of a modified IMC time-delayed system .....	52
Figure (4.25):	IMC structure of the proposed system .....	53
Figure (4.26):	Modified IMC structure of the proposed system .....	53
Figure (4.27):	Response of both controllers to the proposed system.....	53



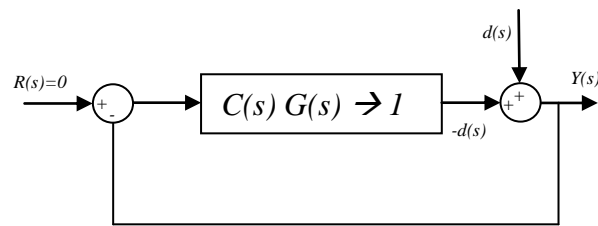
# CHAPTER 1 INTRODUCTION

## 1.1. Introduction

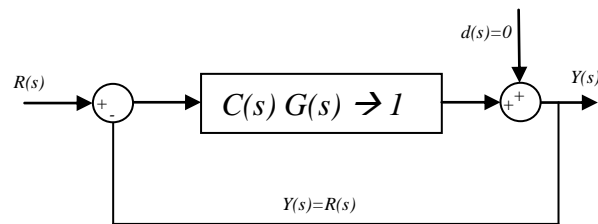
Every feedback controller is designed by employing some form of a model for the process that is to be controlled and/or the dynamics of the exogenous signal affecting the process. Consequently, the term "model-based" is often used here. 30-years ago, a new model-based controller design algorithm named "Internal Model Control" (IMC) has been presented by Garcia and Morari [1], which is developed upon the internal model principle to combine the process model and external signal dynamics.

The IMC controller is a model based controller, and is considered to be robust. Mathematically, robust means that the controller must perform to specification, not just for one model but also for a set of models [2]. The IMC controller design philosophy adheres to this robustness by considering all process model errors as bounded and stable (including transport lag differences between the model and the physical system).

The theory of IMC states that *"control can be achieved only if the control system encapsulates, either implicitly or explicitly, some representation of the process to be controlled"* [1]. In particular, if the control scheme has been developed based on an exact model of the process, then perfect control is theoretically possible.



(a) Block Diagram of IMC for Regulatory Controller



(b) Block Diagram of IMC for Servo Controller

**Figure (1.1): Block Diagram of IMC**

Control system problems divided into a regulatory and a servo control problem. A regulatory controller is a controller in which the setpoint is kept constant and only the disturbances affect the control system. On the other hand the servo control problem is a

tracking problem in which the setpoint is varied as desired and the output should kept to track this point against any disturbances or noises as shown in Figure 1.1.

IMC technique will play the role of system inverter or reciprocal that makes the system acts as transfer function of unity in which it guarantees the output to track the input instantaneously and by ideal shape response and this compact will be discussed later.

## 1.2. Motivation

The main stimulus of choosing this thesis is the huge progress in control systems design that allow to a valuable ideas and concepts to be developed to serve this field resulting a good contribution that make the control problem easier and guarantee the response.

IMC scheme is one of the strongest techniques that raise these motivations:

- 1- IMC technique has been used in many linear systems to control its states and it is considered as a robust controller while the process model is near from the real plant. In this thesis, we will apply the IMC technique on the non-linear pendulum system, which is not tested before.
- 2- Because of the non-linearity of the pendulum system and the IMC demands a model of the plant, so we will be directed to get the linearized form as our base model. Then the distance between the real process and the plant model is increased and it will be a good challenge to IMC to be approved.
- 3- As the gap between the process model and the plant was increased, the uncertainty of the system also increased and the IMC here will be tested for robustness as the parameters values will be varied.
- 4- A new proposed approach of IMC technique was suggested to be put under the same mentioned circumstances, tested and compared with the traditional one. The new approach modifies some blocks in the structure of IMC to get better results.

## 1.3. Objectives

The main objective is to design an IMC Controller for the proposed pendulum system by the traditional and the new approach that:

1. Can regulate the angle of the pendulum rod regardless of the cart position.
2. Satisfy the response specification.
3. Reduce the effect of disturbance due to mismatching in modeling.
4. Achieve the robustness of the controlled system.
5. Comparing results of the two approaches (traditional and new proposed one).

## 1.4. Contribution

The concentration of this research revolves around two main axes:

1. Suggest a new approach for IMC structure and compare it with the traditional one.
2. Apply the new approach controller to regulate the angle of pendulum system depending on the model mentioned before.
3. Propose a solution to make modified IMC (the new approach) deals with systems with time delay and unstable systems.

## 1.5. Literature review

*Scott A. Geddes*, investigated the control of air-temperature in a fruit dehydrator by firstly implementing a PID controller then an IMC controller, and a performance comparison between the PID and IMC controllers was conducted. The IMC controller provided us with the time delay compensation that the PID could not. Not only for a fixed transport-delay but for any delay value he chose [3]. However, the approach was not applied to nonlinear systems.

*Jiliang Shang, Guangguang Wang*, used the principle of Internal Model Control and applied to boiler burning system with large time delay. The simulation showed that the result was improved compared with PID control [4]. It was not use this principle to be applied on nonlinear Pendulum system.

*Caifen Fu, Wen Tan*, presented two IMC approaches that are applied to the active control of combustion instability. It was observed that the direct IMC approach needs to find exact cancellation of the unstable poles for design and implementation thus is not proper for the control of combustion instability; instead, two-step IMC approach can retain the IMC structure if a simple feedback controller can be found to stabilize the process. Simulations show that two-step IMC controller can achieve better disturbance rejection performance [5]. Our design of IMC will use the same principle to stabilize the system first, but the second step will use the new proposed IMC to achieve the perfect control of the process.

*JIN Qi-bing, FENG Chun-lei, LIU Ming-xin*, proposed a PD controller to traditional IMC structure. Simulations showed that the improved IMC method is not only effective for the dynamics and the stability of control system but also effective for the process robustness [6]. The drawback is using a second controller beside IMC.

*Wen Tan, Horacio J. Marquez, Tongwen Chen*, proposed a modified IMC structure for unstable systems with time delays. The structure extends the standard IMC structure for stable processes to unstable processes and they suggest new tuning parameters. The parameters can be tuned and achieve good tradeoff between time-domain performance

and robustness. The drawback is the tuning operation that makes the tradeoff sometimes unacceptable [7].

*Kou Yamada*, proposed a modified IMC for unstable systems and a new structure did not lose the advantages of IMC. The disadvantage here is the complexity of the structure and does not guarantee the stability if a time delay is added [8].

*Hiroki Shibasaki, Manato Ono, Naohiro Ban and Kazusa Matsumoto*, proposed a design of smith compensator using modified IMC for an unstable plant with time delay. An unstable plant with time delay is controlled by the method of a predicted-state feedback. In addition, they introduce a disturbance compensator to overcome the problem in the predicted-state feedback. Furthermore, the system was confirmed high robustness. However, this method demands a tuned parameters and an observer beside a PI controller that in all make the overall system is complex [9].

## **1.6. Research outline**

This dissertation is divided into the following chapters:

*Chapter 2* discusses the theory of the Internal Model Control principle, concern on its limitations and illustrates the way of IMC design for stable and unstable systems and how much the degree of robustness against the classical controller.

*Chapter 3* puts the rules and ideas for the new approach of IMC, shows the differences between the traditional and the new way in design and implementation and compares the advantages and disadvantages against each other.

*Chapter 4* shows how the IMC is response by applying the two ways on the pendulum system and comparing them to get the results.

*Chapter 5* concludes this thesis and makes some notes on proposed future work.

## CHAPTER 2 INTERNAL MODEL CONTROL

### 2.1. Introduction

In the control theorem, the control systems design is fundamentally determined by the steady state and dynamic behavior of the process to be controlled. It is an important issue to know the way in which the process characteristics influence the controller structure. The internal model control (IMC) viewpoint appeared as alternative to traditional feedback control algorithm, which link the process model with the controller structure.

During the late 1950, an investigation of Newton, Gould and Kaiser pointed out the transformation of the closed loop structure into an open one [10] and when Smith proposed a predictor to eliminate the dead time from the control loop [9]. Brosilow, with his inferential control system, also addressed the IMC structure [11]. However, it was Morari and Garcia who brought the major contribution for the advance of the new control structure and reveal it in distinct theoretical framework [12].

The IMC approach to controlling a process has, at its basics, a very human style. When the operator, in manual mode, attempts to maintain a controlled variable close to a desired setpoint, he or she performs a simple calculation based on their intuitive representation (model) of the process in order to set the proper value of the manipulated variable. The operator calculates the difference between the actual value of the controlled output and estimation (prediction) of the effect of the intended value of the manipulated variable on the plant output. The calculation of this difference is the basic information on which relies the decision to set the amplitude of the manipulated variable change that is sent to the plant. In fact, the operator determines the necessary change of the manipulated variable on a model-based estimation (performed in their mind) of the disturbance. Successive iterations of this procedure lead to a desired behavior of the controlled variable. The same fundamental control approach serves as the core of the internal model control.

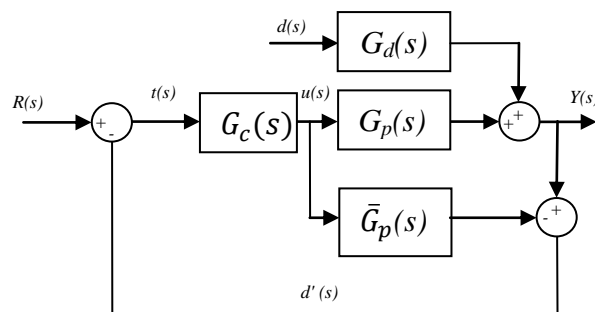


Figure (2.1): Schematic Representation of the Internal Model Control Structure

A schematic representation of the IMC structure is presented in Figure 2.1 in which  $G_p(s)$  represents the process itself.  $G_d(s)$  the process transfer function of the disturbance,  $\bar{G}_p(s)$  the mathematical model (transfer function) of the process, and  $G_c(s)$  the transfer function of the IMC controller.

As may be observed from the block diagram of the IMC structure, there are two parallel paths starting from the manipulated variables  $u(s)$ : one passing through the real process  $G_p(s)$  and the other passing through the model process  $\bar{G}_p(s)$ . The role of the parallel containing the model  $\bar{G}_p(s)$  is to make possible the generation of the difference between the actual process output  $y(t)$  and an estimation (model-based predication) of the manipulated variable effect on the process output. Assuming that the process model is a perfect representation of the real process  $\bar{G}_p(s) = G_p(s)$ , the difference  $d'(s)$  represents the estimated effect of the disturbances (both measured and unmeasured) on the controlled variable. If the process model is not perfect, the difference  $d'(s)$  includes both the effect of disturbances on the output variable and the process-model mismatch. The feedback of the control system is zero when the model is perfect and there are no disturbances, resulting in a control loop being open loop. This fact leads to one of the most important conceptual usefulness of the IMC structure referring to the stability issue. Namely, that the IMC control loop is stable if and only if the process  $G_p(s)$  and the IMC controller  $G_c(s)$  are stable, provided that the model is a perfect representation of the process model and the process is stable. It is only necessary to focus on IMC controller design for avoiding difficulties associated with usual feedback stability problems.

Considering again the control structure of Figure 2.1, the disturbance estimation  $d'(s)$  may be regarded as a correction for the setpoint  $R(s)$  in order to generate an improved target variable  $t(s)$  that allows the IMC controller to produce the manipulated variable able to eliminate the disturbance estimation. It is also interesting to note that the IMC controller acts as a feed-forward controller having the important incentive of counteracting the effect of the unmeasured disturbances, as the feedback signal also represents the estimation of their effect on the process output and the controller setpoint is adjusted consequently.

Even when the model of the process is not perfect and the model error determines a feedback signal in the true sense, it is possible to find the ideal IMC controller  $G_c(s)$  to assure stability, with the only condition that the process is stable by itself.

The application of this principle can be seen in Figure 2.2.

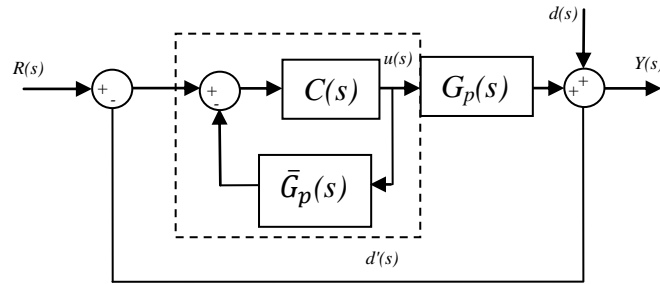
Then the inner loop can be combined as a new controller,  $G_c(s)$ , which is

$$G_c(s) = \frac{C(s)}{1 + G_p(s)C(s)} \quad (2.1)$$

If controller  $C(s)$  is a proportional controller, we find that



$$G_c(j\omega) = \frac{K}{1 + KG_p(j\omega)} \quad (2.2)$$



**Figure (2.2): Application of IMC**

Thus, the internal model principle produces the following implications [13]:

(a) Suppose that  $|G_p(j\omega)|$  is "large" over the frequency range of interest. If the controller  $C(s) = K$ , with  $K \gg 1$ , then the return difference  $|1 + G_c(j\omega) * G_p(j\omega)|$  is "large."

Thus, one can show that the closed loop generates a good approximation of  $G(s)$  for large enough  $K$  (stability robustness should be maintained). Therefore, such a controller generates implicitly satisfactory internal models of stable exogenous signals early on in the transient response, and thus provides good performance.

(b) If  $|G_p(j\omega)|$  is small over a large segment of the frequency range of interest, e.g., very slow processes, then in order to retain the return difference  $|1 + G_p(j\omega) * G_c(j\omega)|$  "large" enough, the controller  $G_c(s)$  should be augmented to include the dynamics of  $R(s)$  or  $d(s)$  changes.

Further, the compensator should provide explicitly internal models of the exogenous signal's dynamics.

(c) For unstable external signals, the loop must generate exact internal models of the inputs,  $R(s)$  and/or  $d(s)$ .

## 2.2. IMC System Theory

The goal of control system design is fast and accurate set point tracking

$$y \approx r \quad \forall t, \forall d \quad (2.3)$$

This implies that the effect of external disturbances should be corrected as efficiently as possible (good regulatory behavior)

$$y' \approx r - d \quad \forall t, \forall d \quad (2.4)$$

Furthermore, the control system designer wishes to obtain (2.3) and (2.4), while also being assured of insensitivity to modeling error. It is well-known that an open-loop

(feedforward) arrangement (Figure 2.3A) represents the optimal way to satisfy (2.3). For the open-loop scheme, the stability question is trivial (the system is stable when both the controller and the system are stable); also the controller is easy to design  $G_c(s) = \bar{G}_p^{-1}(s)$ . The disadvantages are the sensitivity of the performance to plant/model mismatch and the inability to cope with unmeasured disturbances. Plant /model mismatch can be caused, for example, by model reduction (the representation of a high order system by a low order approximate model) or by system parameters which depend on the operating conditions [14].

With the feedback arrangement (Figure 2.3B), the situation is reversed. Plant/model mismatch and unmeasured disturbances can be dealt with effectively, but tuning is complicated by the closed-loop stability problem. We can now augment the open-loop and closed-loop systems as indicated in Figure 2.3C and 2.3D without affecting performance. In Figure 2.3C,  $d = 0$ , and therefore the system is still open-loop; in Figure 2.3D, the two blocks  $\bar{G}_p(s)$  cancel each other by block diagram simplification. Relating Figure 2.3C and 2.3D through the definitions

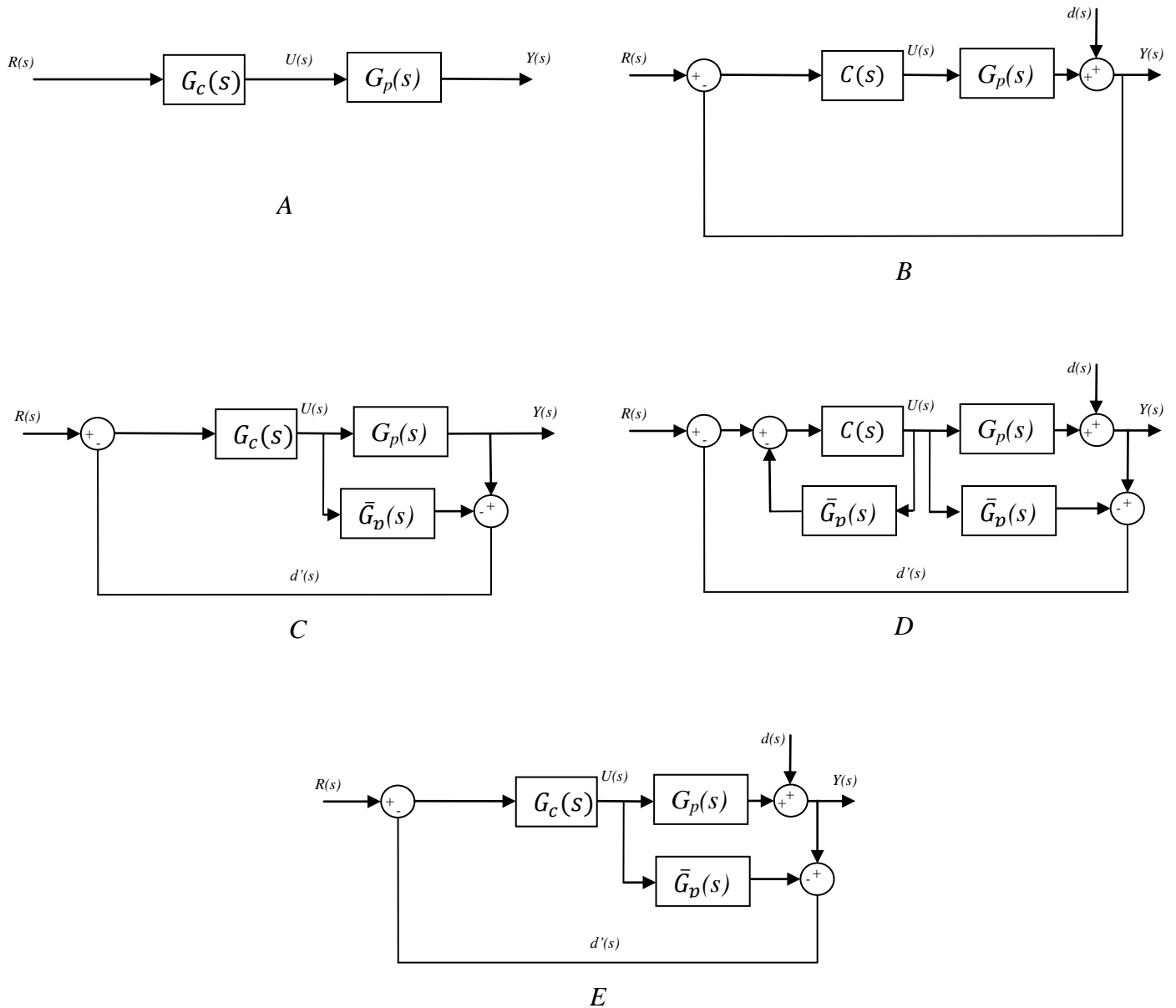
$$G_c(s) = \frac{C(s)}{1 + C(s)\bar{G}_p(s)} \quad (2.5)$$

$$C(s) = \frac{G_c(s)}{1 - G_c(s)\bar{G}_p(s)} \quad (2.6)$$

We arrive at the general structure in Figure 2.3E which has the advantages of both the open loop and closed-loop structures: When the model of the plant is perfect ( $\bar{G}_p(s) = G_p(s)$ ) and there are no disturbances ( $d = 0$ ), feedback is not needed and structure E behaves identically to structure A, informs us of two things:

- Assuming we have complete knowledge of the process (encapsulated in the process model) being controlled, then perfect control can be achieved.
- Feedback is only necessary when knowledge about the process is inaccurate or incomplete.

Because the plant model  $\bar{G}_p(s)$  appears explicitly in E, this structure is referred to as the Internal Model Control (IMC) structure. As a simplification, we can say that the controller in E can be designed with the ease of an open loop controller while retaining the benefits of a feedback system. It is our goal to describe, in detail, such a design procedure.



**Figure (2.3): Evolution of the IMC structure: (A) Open loop (feedforward) system (B) Feedback system (C) IMC without disturbance input (D) IMC with disturbance input (E) Final structure of IMC with disturbance input**

From the block diagram for the IMC structure (Figure 2.3E), follow the relationships below.

The output,  $Y(s)$ , is compared with the output of the process model, resulting in signal  $d'(s)$ ,

$$d'(s) = [G_p(s) - \bar{G}_p(s)] U(s) + d(s) \quad (2.7)$$

if  $d(s)=0$  then  $d'(s)$  is a measure of the difference in behavior between the process and its model.

If  $\bar{G}_p(s) = G_p(s)$ , then  $d'(s) = d(s)$ .

Thus  $d'(s)$  is considered the missing information in the process model  $G_p(s)$ , and therefore can be used to improve control.

Then  $d'(s)$  is used to subtract from the setpoint  $R(s)$  here below,

$$U(s) = [R(s) - d'(s)]G_c(s) \quad (2.8)$$

$$U(s) = [R(s) - [G_p(s) - \bar{G}_p(s)]U(s) + d(s)]G_c(s) \quad (2.9)$$

$$U(s) = \frac{[R(s) - d(s)]G_c(s)}{1 + [G_p(s) - \bar{G}_p(s)]G_c(s)} \quad (2.10)$$

Substitute  $U(s)$ , into output  $Y(s)$  below,

$$Y(s) = G_p(s)U(s) + d(s) \quad (2.11)$$

The closed-loop expression of the system

$$Y(s) = \frac{G_c(s)G_p(s)R(s) + [1 - G_c(s)\bar{G}_p(s)]d(s)}{1 + [G_p(s) - \bar{G}_p(s)]G_c(s)} \quad (2.12)$$

If  $G_c(s) = \bar{G}_p^{-1}(s)$  and  $\bar{G}_p(s) = G_p(s)$ , then theoretically zero error setpoint tracking and disturbance rejection can both be achieved.

If  $\bar{G}_p(s) \neq G_p(s)$  zero error disturbance rejection can be achieved, provided that  $G_c(s) = \bar{G}_p^{-1}(s)$  yields the term  $[1 - G_c(s)\bar{G}_p(s)]d(s) = 0$ .

Four properties can be shown which suggest the advantages of this structure [15].

**P1: Dual Stability.** Assume  $\bar{G}_p(s) = G_p(s)$ . Then the system is effectively open-loop and "closed-loop stability" is implied by the stability of  $G_p(s)$  and  $G_c(s)$ :

$$Y(s) = G_p(s)G_c(s)(R(s) - d'(s)) + d(s) \quad (2.13)$$

While for the classical structure (Figure 2.3B) it is not at all clear what type of controller  $C(s)$  and what parameter choices lead to closed-loop stable systems, the IMC structure guarantees closed-loop stability for all stable controllers  $G_c(s)$ .

The difficulty of analyzing closed-loop stability in terms of the parameters of the controller  $C(s)$  has been removed by the IMC structure. The problem if the plant is open loop unstable the IMC cannot be used before an unstable plant is stabilized. Furthermore, it is impossible in practice to hope that the controller can cancel the unstable poles of the plant exactly. For the issue of stability, the question of the best choice for  $G_c(s)$  arises.

**P2: Perfect Control:** Under the assumption that  $G_c(s) = \bar{G}_p^{-1}(s)$  and that  $G_p(s)$  is stable, the sum of the squares of errors is minimized for both the regulator and the servo-controller when

$$G_c(s) = \frac{1}{G_p(s)} \quad (2.14)$$

If Equation (2.14) is realizable, i.e., if the IMC system is closed-loop-stable, then  $y(t) = r(t)$  at all  $t > 0$  and for all disturbances  $d(t)$ . This perfect control performance can generally not be achieved in practice. Furthermore, if the perfect controller is used, the system will be very sensitive to modeling errors.

**P3: Type-1 System.** Assume that the controller steady-state gain is equal to the inverse of the model gain

$$G_c(0) = \bar{G}_p^{-1}(0) \quad (2.15)$$

and that the closed-loop system in Figure 2.3E is stable. Then the system is of type 1 and the control error vanishes asymptotically for all asymptotically constant inputs  $r(t)$  and  $d(t)$ . This property implies no offset at steady state or zero steady state error.

**P4: Type-2 System.** Select  $G_c(s)$  to satisfy P3 and

$$\frac{d}{ds} \bar{G}_p(s) G_c(s) \Big|_{s=0} = 0 \quad (2.16)$$

Then the system is of type 2 and the control error vanishes asymptotically for all asymptotically ramp-shaped inputs  $r(t)$  and  $d(t)$ .

P1 simply expresses the fact that in the absence of plant/model mismatch, the stability issue is trivial, as long as the open-loop system is stable. P2 asserts that the ideal open-loop controller leads to perfect closed-loop performance when the IMC structure is employed. P3 and P4 state that inherent integral action can be achieved without the need for introducing additional tuning parameters. P2, however, represents an idealized situation. We know intuitively that P2 requires an infinite controller gain; this is confirmed by substituting  $G_c(s) = \bar{G}_p^{-1}(s)$  in equation (2.6). By setting  $G_c(0) = \bar{G}_p^{-1}(0)$  as postulated for P3, we find  $C(0) = \infty$ , which implies integral control action, as expected.

There are several reasons why the "perfect controller" implied by P2 cannot be realized in practice [15].

1. **Right-Half Plane (RHP) Zeros:** If the model has a RHP zero, the controller  $G_c(s) = \bar{G}_p^{-1}(s)$  has a RHP pole, and if  $\bar{G}_p(s) = G_p(s)$ , the closed-loop system will be unstable according to P1.
2. **Time Delay:** If the model contains a time delay, the controller  $G_c(s) = \bar{G}_p^{-1}(s)$  is predictive and cannot be realized.
3. **Constraints on the Manipulated Variables:** If the model is strictly proper, then the perfect controller  $G_c(s) = \bar{G}_p^{-1}(s)$  is improper, which implies

$\lim_{w \rightarrow \infty} |G_c(s)| = \infty$ . Thus, infinitely small high-frequency disturbances would give rise to infinitely large excursions of the manipulative variables which are physically unrealizable.

**Definition 2.1:**

A system is called a proper system if the quantity

$$\lim_{|s| \rightarrow \infty} G_p(s) < \infty \quad (2.17)$$

must be finite. We say  $G_p(s)$  is strictly proper if

$$\lim_{|s| \rightarrow \infty} G_p(s) = 0 \quad (2.18)$$

A strictly proper transfer function has a denominator order greater than the numerator order.  $G_p(s)$  is semi-proper, that is,

$$\lim_{|s| \rightarrow \infty} G_p(s) > \infty \quad (2.19)$$

if the denominator order is equal to the numerator order.

A system that is not strictly proper or semiproper is called improper.

4. **Modeling Error:** If  $G_p(s) \neq \bar{G}_p(s)$  P1 does not hold and the closed-loop system will generally be unstable for the controller  $G_c(s) = \bar{G}_p^{-1}(s)$ .

However, it is normally impossible to obtain the inverse of a real process transfer function completely, due to several practical limitations [1] :

- (a) We can only design a controller that is the inverse of a process model transfer function, because the process is never known exactly.
- (b) To take the inverse of a real process transfer function completely implies infinite controller gain, which leads to unrealizable situations given that all manipulated variables are subject to physical bounds.
- (c) If the process dead time and/or the right-half plane (RHP) process zeros are presented in the process transfer function, the complete inverse of a process model would lead to either an unrealizable or an unstable controller.

Therefore, only the approximate model of  $G_p(s)$  can be achieved. The idea of designing a controller as an inversion of an approximate process model is one of the major concepts in designing the IMC controller. Based on the internal model principle, the model can be subtracted and processed in front of the controller.

This directs us to define what we called the invertibility of the system.

**Definition 2.2:**

A system  $G_p(s)$  can be called invertible if  $G_p(s)$  contains only a minimum phase terms.

If we augment, the condition of properness such that  $\bar{G}_p^{-1}(s)$  is proper then  $G_p(s)$  is strictly invertible.

**Definition 2.3:**

A minimum phase transfer function has only zeros in the left half of the s-plane (i.e., the zeros are all negative). A non-minimum phase transfer function has one or more zeros in the right half of the s-plane. A deadtime is often called a nonminimum

phase element because it cannot be inverted and it is in that way similar to a nonminimum phase transfer function, which also does not have a stable inverse.

In resolving these issues, the ideal of perfect control must be abandoned. The IMC design procedure handles this in two steps; first, performance is addressed with no regard to robustness or input constraints. Second, a filter is introduced and designed for properness (input constraints) and robustness without looking at how this affects the performance. Though there obviously does not exist any separation principle which makes this approach "optimal", the design procedure is very simple and direct.

### 2.3. Requirements for physical realizability on the IMC controller

In order for  $G_c(s)$ , the IMC controller, to result in physically realizable manipulated variable responses, it must satisfy the following criteria:

1. *Stability*: The controller must generate bounded responses to bounded inputs; therefore, all poles of  $G_c(s)$  must lie in the open Left-Half Plane.
2. *Properness*: We knew that differentiation of step inputs by a feedback controller leads to impulse changes in  $u$ , which are not physically realizable. In order to avoid pure differentiation of signals, we must require that  $G_c(s)$  be proper.
3. *Causality*:  $G_c(s)$  must be causal, which means that the controller must not require prediction, i.e., it must rely on current and previous plant measurements. A simple example of a noncausal transfer function is the inverse of a time delay transfer function

$$G_c(s) = \frac{u(s)}{e(s)} = K_c e^{\theta s} \quad (2.20)$$

The inverse transform of (2.20) relies on future inputs to generate a current output; it is clearly not realizable.

$$u(t) = K_c e(t + \theta) \quad (2.21)$$

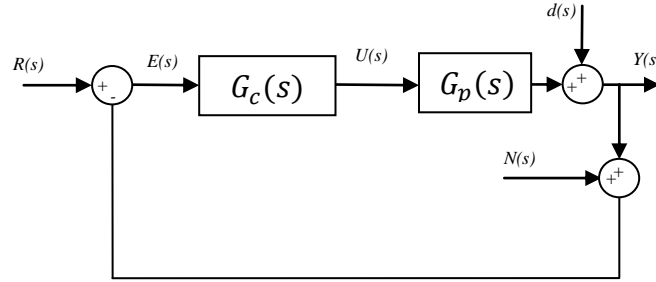
## 2.4. Sensitivity Function

### 2.4.1. Overview

One of the performance objectives of controller design is to keep the error between the controlled output and the set-point as small as possible, when the closed-loop system is affected by external signals. Thus, to be able to assess the performance of a particular control, we need to be able to quantify the relationship between this error, the process and the controller [16].

In this section, we will take a brief look at one such quantifying measure, the sensitivity function and its counterpart, the complementary sensitivity function. We shall see that

in the case of a conventional closed loop system, the sensitivity function relates to disturbance rejection properties while the complementary sensitivity function provides a measure of set- point tracking performances. We shall also discover that, through the relationship between these two functions, why we often have to sacrifice one aspect in favor of the other. In the following discussion, we shall be considering the conventional feedback loop shown in the Figure 2.4.



**Figure (2.4): Schematic of conventional feedback control loop.**

#### 2.4.2. Sensitivity Function

The sensitivity function that we will use is defined in the Laplace domain as:

$$\varepsilon(s) = \frac{E(s)}{R(s) - d(s)} \quad (2.22)$$

Thus the sensitivity function,  $\varepsilon(s)$ , relates the external inputs,  $R(s)$  and  $d(s)$ , to the feedback error  $E(s)$ . Notice, however, that it does not take into account the effects caused by the noise,  $N(s)$ .

From the block diagram in Figure 2.4, we can see that

$$E(s) = R(s) - Y(s) = R(s) - [G_p(s).U(s) + d(s)] \quad (2.23)$$

But, 
$$U(s) = G_c(s).E(s) \quad (2.24)$$

Then, 
$$E(s) = R(s) - G_c(s)G_p(s)E(s) - d(s) \quad (2.25)$$

Rearranging, 
$$E(s)[1 + G_c(s)G_p(s)] = R(s) - d(s) \quad (2.26)$$

Hence, 
$$\frac{E(s)}{R(s) - d(s)} = \frac{1}{1 + G_c(s)G_p(s)} \quad (2.27)$$

Since, 
$$\frac{Y(s)}{d(s)} = \frac{1}{1 + G_c(s)G_p(s)} \quad (2.28)$$



It follows that,

$$\varepsilon(s) = \frac{E(s)}{R(s) - d(s)} = \frac{Y(s)}{d(s)} \quad (2.29)$$

Thus, the sensitivity function has an important role to play in judging the performance of the controller because it also describes the effects of the disturbance,  $d(s)$ , on the controlled output,  $Y(s)$ . For the controller to achieve good disturbance rejection, it is obvious that  $\varepsilon(s)$  should be made as small as possible by an appropriate design for the controller,  $G_c(s)$ . In particular,  $\varepsilon(s) = 0$  if perfect control is achievable [17].

However, most physical systems are strictly proper. In terms of their transfer function representation, this means that the denominator of the transfer function is always of higher order than the numerator. Thus,

$$\lim_{s \rightarrow \infty} G_c(s)G_p(s) = 0 \quad (2.30)$$

In the frequency domain, this becomes

$$\lim_{\omega \rightarrow \infty} G_c(j\omega)G_p(j\omega) = 0 \quad (2.31)$$

Hence,

$$\lim_{\omega \rightarrow \infty} \varepsilon(j\omega) = \lim_{\omega \rightarrow \infty} \frac{1}{1 + G_c(j\omega)G_p(j\omega)} = 1 \quad (2.32)$$

Thus, on the one hand,  $\varepsilon(j\omega)$  has to be close to zero for ideal disturbance rejection, while on the other, at high frequencies,  $\varepsilon(j\omega)$  is one.

What the results are telling us is that perfect control cannot be achieved over the whole frequency range. Indeed, the analysis shows that perfect control can only be achieved over a small range of frequencies, at the low frequency end of the frequency response, i.e. near steady state.

### 2.4.3. Complementary Sensitivity Function

The complementary sensitivity function is, as suggested by the name, defined as:

$$\eta(s) = 1 - \varepsilon(s) \quad (2.33)$$

If there is no measurement noise, i.e.  $N(s) = 0$ , then since

$$\varepsilon(s) = \frac{1}{1 + G_c(s)G_p(s)} \quad (2.34)$$

$$\eta(s) = 1 - \frac{1}{1 + G_c(s)G_p(s)} = \frac{G_c(s)G_p(s)}{1 + G_c(s)G_p(s)} = \frac{Y(s)}{R(s)} \quad (2.35)$$

In this case, the complementary sensitivity function simply relates the controlled variable  $Y(s)$  to the desired input,  $R(s)$ . Thus, it is clear that  $\eta(s)$  should be as close as possible to 1 by an appropriate choice of controller. Again, since most physical processes are strictly proper in the open loop, i.e.

$$\lim_{s \rightarrow \infty} G_c(s)G_p(s) = 0 \quad (2.36)$$

this means that, in the frequency domain,

$$\lim_{w \rightarrow \infty} \eta(j\omega) = \lim_{w \rightarrow \infty} \frac{G_c(j\omega)G_p(j\omega)}{1 + G_c(j\omega)G_p(j\omega)} = 0 \quad (2.37)$$

As in the case of the sensitivity function,  $\varepsilon(j\omega)$ , the desired value of the complementary sensitivity function,  $\eta(j\omega)$ , can be achieved only near low frequencies.

#### 2.4.4. Effects of measurement noise

If there is process noise, i.e.  $N(s) \neq 0$ , then

$$\eta(s) = \frac{G_c(s)G_p(s)}{1 + G_c(s)G_p(s)} = \frac{Y(s)}{R(s) - N(s)} \quad (2.38)$$

Thus, the structure of  $\eta(s)$  is identical to the noise free case for the feedback loop that we are considering (Figure 2.4).

#### 2.4.5. The trade-off between robustness and performance

Notice that when there is process noise, in terms of process inputs and outputs,  $\eta(s)$  is now also affected by  $N(s)$ . In this case,  $\eta(s)$  has to be made small so as to reduce the influence of random inputs on system characteristics. In other words, we want  $\eta(s) = 0$  or equivalently,  $\varepsilon(s) = 1$ . Compare this with the noise free situation where we require  $\eta(s) = 1$  or  $\varepsilon(s) = 0$ . This illustrates the compromise that often has to be made in control systems design: good set-point tracking and disturbance rejection has to be traded off against suppression of process noise.

From the above discussion, we can make the following observations:

- Both  $\varepsilon(s)$  and  $\eta(s)$  have minimum values equal to 0 and maximum values equal to 1.
- When there is no measurement noise,
  - For perfect disturbance rejection,  $\varepsilon(s) = 0$ .
  - For perfect set-point tracking,  $\eta(s) = 1$ .
  - Perfect disturbance rejection also implies perfect set-point tracking.

- When measurement noise is present  $\eta(s) = 0$  or equivalently,  $\varepsilon(s) = I$ , so as to reduce the influence of random inputs on system performance.

## 2.5. Internal Model Control Design Procedure

The IMC design procedure is a two-step approach that, although sub-optimal in a general (norm) sense, provides a reasonable tradeoff between performance and robustness. The main benefit of the IMC approach is the ability to directly specify the complementary sensitivity and sensitivity functions  $\eta$  and  $\varepsilon$ , which as noted previously, directly specify the nature of the closed-loop response.

The IMC design procedure consists of two main steps. The first step will insure that  $G_c(s)$  is stable and causal; the second step will require  $G_c(s)$  to be proper.

*Step 1:* Factor the model  $\bar{G}_p(s)$  into two parts:

$$\bar{G}_p(s) = \bar{G}_{p+}(s) \cdot \bar{G}_{p-}(s) \quad (2.39)$$

$\bar{G}_{p+}(s)$  contains all Nonminimum Phase Elements in the plant model, that is all Right-Half-Plane (RHP) zeros and time delays. The factor  $\bar{G}_{p-}(s)$ , meanwhile, is Minimum Phase and invertible as stated in *Def 2.2 and 2.3*.

Then an IMC controller defined as

$$G_c(s) = \bar{G}_{p-}^{-1}(s) \quad (2.40)$$

is stable and causal.

The factorization of  $\bar{G}_{p+}(s)$  from  $\bar{G}_p(s)$  is dependent upon the objective function chosen. For example,

$$\bar{G}_{p+}(s) = e^{-\theta s} \prod_i (-B_i s + 1) \quad \text{Re}(B_i) > 0 \quad (2.41)$$

is Integral-Absolute-Error (IAE)-optimal for step setpoint and output disturbance changes. Meanwhile, the factorization

$$\bar{G}_{p+}(s) = e^{-\theta s} \prod_i \frac{(-B_i s + 1)}{(B_i s + 1)} \quad \text{Re}(B_i) > 0 \quad (2.42)$$

is Integral-Square-Error (ISE)-optimal for step setpoint/output disturbance changes. where  $B_i^{-1}$  are all the RHP zeros and  $\theta$  is the time delay present in  $g'$ . Because of this factorization, poles corresponding to the LHP image of the RHP zeroes have been added to the closed-loop response [18].

*Step 2:* To improve robustness, the effects of mismatch between the process, and process model should be minimized. Since the differences between process and the

process model usually occur at the systems high frequency response end, a low-pass filter  $f(s)$  is usually added to attenuate this effect [19]. Thus, IMC is designed using the inverse of the process model in series with a low-pass filter. Augment  $G_c(s)$  with a filter  $f(s)$  such that the final IMC controller is now,

$$G_c(s) = \bar{G}_p^{-1}(s) \cdot f(s) \quad (2.43)$$

In addition to stable and causal, proper. With the inclusion of the filter transfer function, the final form for the closed-loop transfer functions characterizing the system is

$$\eta = \bar{G}_p(s) G_c(s) f(s) \quad (2.44)$$

$$\varepsilon = 1 - \bar{G}_p(s) G_c(s) f(s) \quad (2.45)$$

The inclusion of the filter transfer function in Step 2 means that we no longer obtain “optimal control,” as implied in Step 1. We wish to define filter forms that allow for no offset to Type 1 and Type 2 inputs; for no offset to step inputs (Type 1), we must require that  $\eta(0) = 1$ , which requires that  $G_c(0) = \bar{G}_p^{-1}(0)$  and forces

$$f(0) = 1 \quad (2.46)$$

A common filter choice that conforms to this requirement is

$$f(s) = \frac{1}{(\lambda s + 1)^n} \quad (2.47)$$

The filter order  $n$  is selected large enough to make  $G_c(s)$  proper but it must be noted a large  $n$  can cause a ripple in the response, while  $\lambda$  is an adjustable parameter, which determines the speed-of-response. Increasing  $\lambda$  increases the closed-loop time constant and slows the speed of response; decreasing  $\lambda$  does the opposite.  $\lambda$  can be adjusted on-line by a computer program to compensate for plant/model mismatch in the design of the control system; the higher the value of  $\lambda$ , the higher the robustness the control system.

For no offset to Type-2 (ramp) inputs, in addition to the requirement (2.46), the closed-loop system must satisfy the following

$$\frac{d}{ds} (\bar{G}_p(s) G_c(s))|_{s=0} = \frac{d\eta}{ds}|_{s=0} = 0 \quad (2.48)$$

The choice of the filter parameter  $\lambda$  in Eq. (2.47) depends on the allowable noise amplification by the controller and on modeling errors. Methods for choosing the filter time constant to accommodate modeling errors are discussed below. To avoid excessive noise amplification, we recommend that the filter parameter  $\lambda$  be chosen so that the high

frequency gain of the controller is not more than 20 times its low frequency gain. For controllers that are ratios of polynomials, this criterion can be expressed as

$$G_c(\infty) / G_c(0) \leq 20 \quad (2.49)$$

The criterion given by Eq. (2.49) arises from the standard industrial practice of limiting the high frequency gain of a PID controller to no more than 20 times the low frequency controller gain, which is usually referred to simply as the controller. Factors of 5 and 10 are also frequently encountered in practice.

In addition to this criterion, the filter time constant  $\lambda$  must satisfy [3]:

$$\lambda \geq \left( \lim_{s \rightarrow \infty} \frac{D(s)N(0)}{20s^n N(s)D(0)} \right)^{\frac{1}{n}} \quad (2.50)$$

As before, the limit given by Eq. (2.49) ensures that the high frequency gain of the controller is not more than 20 times its low frequency gain.

The form of the filter (i.e.,  $1/(\lambda s + 1)^n$ ) is somewhat arbitrary. It was chosen because it is the simplest form with a single adjustable parameter,  $\lambda$ , which provides an overdamped response and makes  $G_c(s)$  realizable. Such a filter has the great merit of simplicity at the possible price of being suboptimal. There is also no incentive to use a filter order,  $n$ , greater than the minimum required to make the IMC controller realizable, because when there are modeling errors, higher order filters lead to slower responses. Choosing a filter whose order is the same as the relative order of the model leads to a controller,  $G_c(s)$ , whose relative order is zero.

## 2.6. IMC for systems with time delay

### 2.6.1. Introduction

Real dynamical systems often show some time lag between a change of an input and the corresponding change of the output. This time lag has a whole range of causes. Time-delay often appears in many control systems (such as aircraft, chemical or process control systems) in either the state, the control input, or the measurements. Unlike ordinary differential equations, delay systems are infinite dimensional in nature and time-delay is, in many cases, a source of instability. The stability issue and the performance of control systems with delay are, therefore, both of theoretical and practical importance [7].

For needs of mathematical modeling, it is aggregated into a total phenomenon called time delay or dead time. If a real system with time delay is modeled as a time invariant linear system, its transfer function (rational function) becomes due to time delay a transcendental function. Most of methods used for analysis and synthesis of control systems are developed for transfer functions in the form of rational functions only. If

these methods have to be used also for dynamical systems with time delay then it is necessary to approximate transfer functions of time delay by means of rational functions. Approximations usually use either Padé approximation or Taylor series of the exponential function [7].

The expression of a system with time delay is the transfer function of the system multiplied by  $e^{-\theta s}$ .

Assume that the process is a first-order plus time delay system. Thus, its model has the following general form:

$$G_p(s) = \frac{K e^{-\theta s}}{1 + \tau s} \quad (2.51)$$

At this point, we can proceed in one of the two ways:

1. Series approximation for the time-delay using Taylor:

We can approximate the time delay term using first order series as

$$e^{-\theta s} \approx (1 - \theta s) \quad (2.52)$$

Thus,

$$G_p(s) = \frac{K e^{-\theta s}}{1 + \tau s} \approx \frac{K(1 - \theta s)}{1 + \tau s} \quad (2.53)$$

With

$$G_{p-}(s) = \frac{K}{1 + \tau s} \quad (2.54)$$

$$G_{p+}(s) = (1 - \theta s) \quad (2.55)$$

Because of  $(1 - \theta s)$  is considered now as a RHP zero.

Thus,

$$G_c(s) = G_{p-}^{-1}(s) f(s) = \frac{(1 + \tau s)}{K(1 + \lambda s)} \quad (2.56)$$

2. (Padé approximation): A Padé approximation to the exponential  $e^{-\theta s}$  is a ratio of polynomials of order  $m$  in the numerator, and  $n$  in the denominator, whose coefficients are chosen so that the ratio of polynomials approximates the exponential to within terms of order  $n + m + 1$  in  $s$ . That is, the Maclaurin series expansion in  $s$  of the exponential and its Padé approximation agree through terms of order  $m + n$  [11].

Padé approximation of time delay transfer function meets the weak conditions of physical realizability and introduces unstable zeroes into the transfer function.

So, we can approximate the time delay term with its Padé approximation as

$$e^{-\theta s} \approx \frac{1 - \frac{\theta}{2}s}{1 + \frac{\theta}{2}s} \quad (2.57)$$

In this case

$$G_{p-}(s) = \frac{K}{(1 + \tau s)(1 + \frac{\theta}{2}s)} \quad (2.58)$$

$$G_{p+}(s) = \left(1 - \frac{\theta}{2}s\right) \quad (2.59)$$

Thus,

$$G_c = G_{p-}^{-1}(s)f(s) = \frac{(1 + \tau s)\left(1 + \frac{\theta}{2}s\right)}{K(1 + \lambda s)^n} \quad (2.60)$$

This illustrates a very important attribute of IMC design, that once the process model inverse and the filter has been determined, that the controller is complete. Since the controller has been determined independent of delay term, the IMC controlled system can be designed around any delay value. For example, if a system was designed for a transport delay of 10 seconds, the step response to any other delay value displays the same response of this design except translated by the delay value.

### 2.6.2. Smith Predictor

If a time delay is introduced into a well-tuned system, the gain must be reduced to maintain stability [20]. The Smith predictor control scheme can help overcome this limitation and allow larger gains [21], but it is critical that the model parameters exactly match the plant parameters [22].

Time delays occur frequently in chemical, biological, mechanical, and electronic systems. They are associated with travel times (as of fluids in a chemical process, hormones in the blood stream, shock waves in the earth, or electromagnetic radiation in space), or with computation times (such as those required for making a chemical composition analysis, cortical processing of a visual image, analyzing a TV picture by a robot, or evaluating the output of a digital control algorithm)[23]. Most elementary control theory textbooks deals slight with time-delay systems, because they are more difficult to analyze and design. For example, in time-delay systems initial conditions must be specified for the whole interval from  $-\theta$  to 0, where  $\theta$  is the time delay. For simplicity, in this discussion I assume the initial conditions are zero.

A unity-feedback, closed-loop control system with

$$KGH = \frac{k}{\tau s + 1} \quad (2.61)$$

has a transfer function of

$$\frac{Y(s)}{R(s)} = \frac{k}{\tau s + 1 + k} \quad (2.62)$$

This is stable for  $-1 < k$ . If a time delay of the form  $e^{-\theta s}$  is introduced in the forward path, stability is no longer guaranteed. The transfer function of such a system is

$$\frac{Y(s)}{R(s)} = \frac{k}{\tau s + 1 + ke^{-\theta s}} e^{-\theta s} \quad (2.63)$$

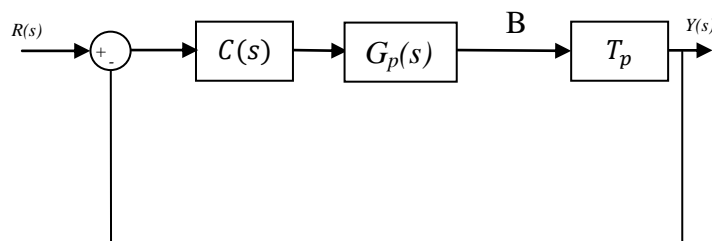
The stability limits are not obvious. The exponential in the numerator does not bother us. The exponential in the denominator will be approximated by an algebraic expression as Taylor series expansion, Pade approximation or others. But each way produces a different ranges of stability for  $k$ . So the approximation methods mentioned are not, in general, good methods for assessing the stability of a system. Sometimes they yield bizarre results [24].

Smith predictor structure is developed to compensate process time delay even if it is long.

The block diagram for conventional control is shown in Figure 2.5. For a simple first order plant with a pure time delay

$$G_p(s) = \frac{k}{\tau s + 1} \quad \text{and} \quad T_p = e^{-\theta s} \quad (2.64)$$

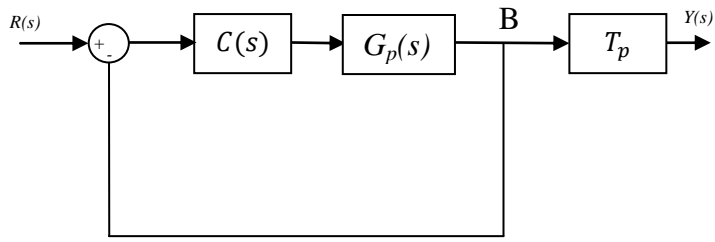
As shown in Figure 2.5, the process can be conceptually split into delay free system dynamics and a pure time delay. If the variable  $B$  could be measured, we could connect it to the controller, as shown in Figure 2.6. This would move the time delay outside the control loop. Since there would be no delay in the feedback signal, the response would be improved.



**Figure (2.5): Typical time delay system and feedback from Y**

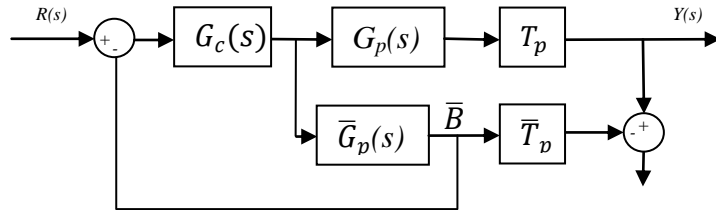
Of course, this cannot be done in a physical system, because the time delay is probably distributed-not lumped-and there is no a priori reason to place the time delay after the plant dynamics rather than before it.



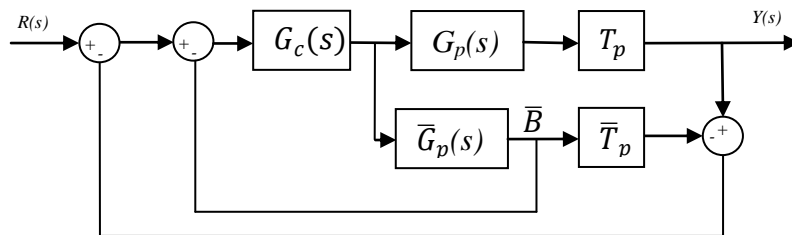


**Figure (2.6): Typical time delay system and feedback from B**

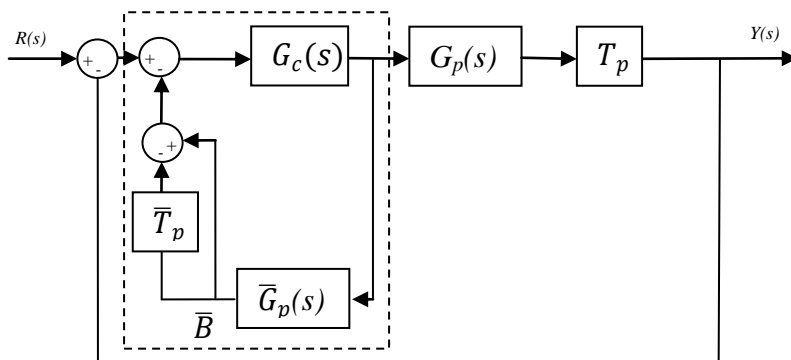
To improve the design let us model the plant as shown in Figure 2.7.



**Figure (2.7): Preliminary form of the Smith Predictor**



**Figure (2.8): Complete form of the Smith Predictor**



**Figure (2.9): Rearrangement of smith predictor control scheme**

For the previous example of a first order process equation 2.64, the variable B is unavailable, but  $\bar{B}$  can be used as the feedback signal. This arrangement controls the model well, but not the overall system. The control of the system output is open loop and a second feedback is needed as in Figure 2.8. Sometimes the smith predictor is drawn as in Figure 2.9 which is equivalent to Figure 2.8 [24].

The closed loop transfer function of the system is

$$\frac{Y(s)}{R(s)} = \frac{G_c(s)G_p(s)T_p}{1 + G_c(s)\bar{G}_p(s) - G_c(s)\bar{G}_p(s)\bar{T}_p + G_c(s)G_p(s)T_p} \quad (2.65)$$

If the model matches the process, this will be reduced to

$$\frac{Y(s)}{R(s)} = \frac{G_c(s)G_p(s)T_p}{1 + G_c(s)\bar{G}_p(s)} \quad (2.66)$$

The effects of the time delay have been removed from the denominator of the transfer function, and the system performance has been improved. However, it tracks input variations with a time delay.

## 2.7. Robustness of IMC

Finally, let us consider the sensitivity functions for the IMC scheme and compare this with those of conventional feedback control stated in section 2.4. We want to do this to see how the change in control structure facilitates the design of robust control systems.

Recall that,

$$\varepsilon(s) = \frac{E(s)}{R(s) - d(s)} = \frac{Y(s)}{d(s)} \quad (2.67)$$

For IMC, since

$$Y(s) = \frac{G_c(s)G_p(s)R(s) + [1 - G_c(s)\bar{G}_p(s)]d(s)}{1 + [G_p(s) - \bar{G}_p(s)]G_c(s)} \quad (2.68)$$

Then,

$$\varepsilon(s) = \frac{1 - G_c(s)\bar{G}_p(s)}{1 + [G_p(s) - \bar{G}_p(s)]G_c(s)} \quad (2.69)$$

by assuming  $R(s) = 0$ . Further, supposing that  $G_p(s) = \bar{G}_p(s)$ , then

$$\varepsilon(s) = 1 - G_c(s)\bar{G}_p(s) \quad (2.70)$$

Therefore, in the IMC strategy, the controller appears linearly in the respective functions. Compare this with the corresponding functions for the conventional control scheme,

$$\varepsilon(s) = \frac{1}{1 + G_c(s)G_p(s)} \quad (2.71)$$

$$\eta(s) = \frac{G_c(s)G_p(s)}{1 + G_c(s)G_p(s)} \quad (2.72)$$

This raises the advantage of IMC that it is easy to shape sensitivity and complementary function. Since the sensitivity function determines performance whilst the complementary sensitivity function determines robustness, this implies that the IMC provides a much easier framework for the design of robust control system.

## 2.8. IMC for Unstable Systems

In the previous sections, we illustrate that IMC has much advantages to design control system for some reasons [8]:

- Stability of IMC is only depending on the stability of the plant and the controller.
- Capability of response shaping using the adjustable parameter  $\lambda$ .
- It is easy for shaping sensitivity function, thus robustness achievement.

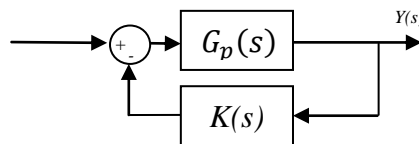
However, IMC can not be applied to unstable plants. In this section, we will introduce a modified IMC system to be able to apply to unstable plants without loss of advantages of characteristics of IMC.

Modification of internal model control is considered from the parameterization of the stabilizing controller based on IMC structure for unstable plants [25].

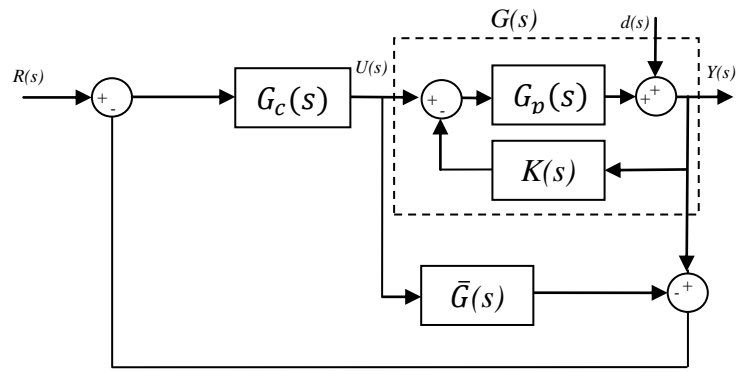
Since  $G(s)$  must be stable, it is considered as a system that is stabilized by using local feedback loop like Figure 2.10, here  $K(s)$  is a stable stabilizing controller of  $G_p(s)$  [8]. That is

$$G(s) = \frac{G_p(s)}{1 + K(s)G_p(s)} \quad (2.73)$$

is asymptotically stable. Where  $G(s)$  is the stabilized system.



**Figure (2.10): Stabilizing unstable system**



**Figure (2.11): Modified IMC scheme**

Then we get a stabilized system  $G(s)$ . Thus, the reference model  $\bar{G}(s)$  will be equal to  $G(s)$  and the IMC controller will be designed for this new system as mentioned in the previous sections of design procedures.

# CHAPTER 3 MODIFIED INTERNAL MODEL CONTROL

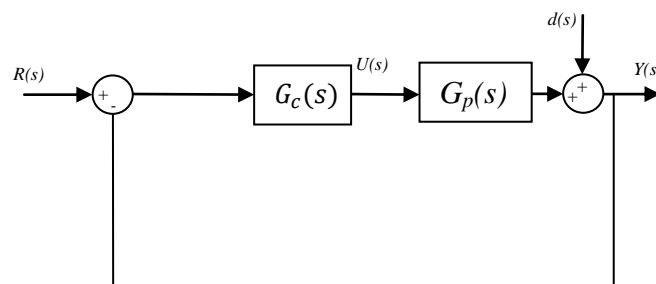
## 3.1. Introduction

In the previous chapter, we talked about the general structure of internal model control and saw the theory of it and its design procedures and realization and the idea concerned on getting the model of the process, reuse it as a reference model parallel to the process, and use it for design. The realization process here requires a double work, once for the model and another for the controller. The parallel reference model is used as mentioned in Chapter 2 for converting all system to open loop system when the mismatch did not exist. However, the feedback in all cases occupying a position and hardware is implemented for it. Then my idea here is to reduce the amount of hardware used for realization and implementation without any additional component. The concept revolves around canceling the parallel reference model and uses the feedback as usual in the traditional control with some modification on the controller design. This concept has advantages and disadvantages which discussed later.

## 3.2. Modified IMC Theory

This section will handle the concept of modified IMC and discuss the theory of it, illustrating the block diagram and design procedures.

The modified block diagram is shown in Figure 3.1



**Figure (3.1): Modified IMC structure**

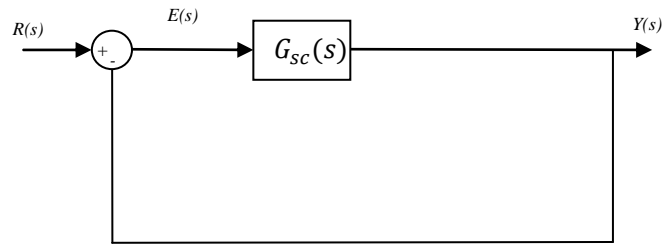
Figure 3.1 illustrates the structure of this approach and we can see disappearance of the reference model compared with Figure 2.3E

The new proposed IMC structure cancel the repeated model appeared in the general IMC structure and present a new  $G_c(s)$  equation.

The new controller idea is trying to cancel the process model  $G_p(s)$  by the term  $G_p(s)^{-1}$  that considered as the inverse of the process transfer function and substitute it by another transfer function  $G_{sc}(s)$  such that:

$$G_c(s) = G_p(s)^{-1} \cdot G_{sc}(s) \quad (3.1)$$

where  $G_{sc}(s)$  is the transfer function that the closed loop of it will achieve the required criteria as shown in Figure 3.2.



**Figure (3.2): Controller Closed Loop System**

The output of the system above is

$$Y(s) = \frac{G_{sc}(s)}{1 + G_{sc}(s)} R(s) \quad (3.2)$$

and we considered that this achieves the specifications required from the original system to be controlled.

The selection of  $G_{sc}(s)$  is trivial and depends on  $Y(s)/R(s)$  that can be assumed a second order system has the form of:

$$\frac{Y(s)}{R(s)} = \frac{\omega_n^2}{s^2 + 2\zeta\omega_n s + \omega_n^2} \quad (3.3)$$

Where

Percent overshoot  $OS\% = e^{-\frac{\pi\zeta}{\sqrt{1-\zeta^2}}} \times 100 \quad (3.4)$

Settling time  $T_s = \frac{4}{\zeta\omega_n} = \frac{4}{\sigma} \quad (3.5)$

Peak time  $T_p = \frac{\pi}{\omega_n \sqrt{1-\zeta^2}} \quad (3.6)$

Then we can extract  $G_{sc}(s)$  from equation 3.2 to get the form

$$G_{sc}(s) = \frac{Y(s)}{R(s) - Y(s)} \quad (3.7)$$

Then if we can imagine the overall system in Figure 3.1, then we can conclude that  $G_c(s) = G_p(s)^{-1} \cdot G_{sc}(s)$  will cancel the process behavior as in Chapter 2 but adds  $G_{sc}(s)$  that guarantees the desired specification to be achieved.

As mention in the previous chapter to get the invertible form of the process we face some problems and guide non invertible parts and guide us to use the method that split the process transfer function to invertible then use the invertible one for design.

Besides that, we put in mind the limitation of the design that mention also in Chapter 2 to make sure the system will be realizable.

### 3.3. Numerical Example

Suppose we have a simple system represent a DC motor with a transfer function of:

$$G(s) = \frac{1.5}{s^2 + 14s + 40.02} \quad (3.8)$$

and want to achieve  $OS\% < 10\%$  and  $T_s < 5$  sec, so at first we want to design  $Y(s)$  to meet the desired design :

$$\frac{Y(s)}{R(s)} = \frac{5.3}{s^2 + 3s + 5.3} \quad (3.9)$$

Then obtain  $G_{sc}(s)$  from  $Y(s)$  such that  $R(s)$  is impulse input

$$G_{sc}(s) = \frac{5.3}{s(s+3)} \quad (3.10)$$

And if we simulate  $G_{sc}(s)$  alone as a closed loop system we will note that it will achieve the requirement.

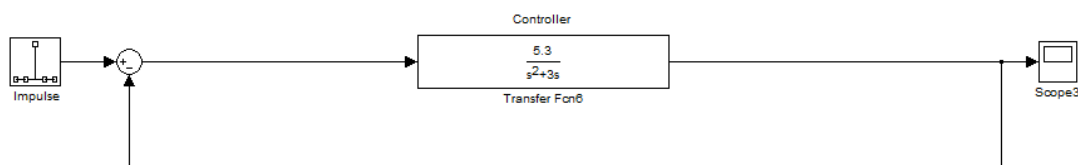
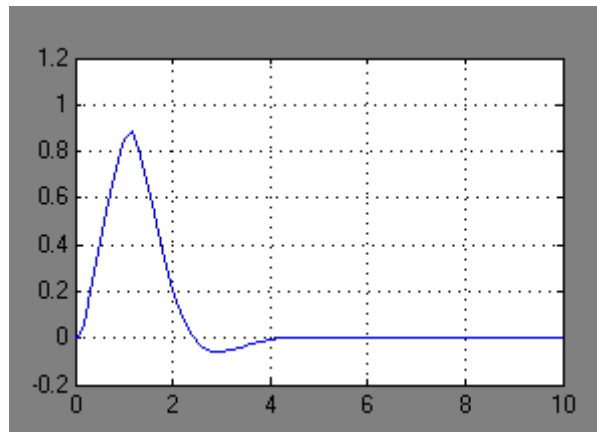
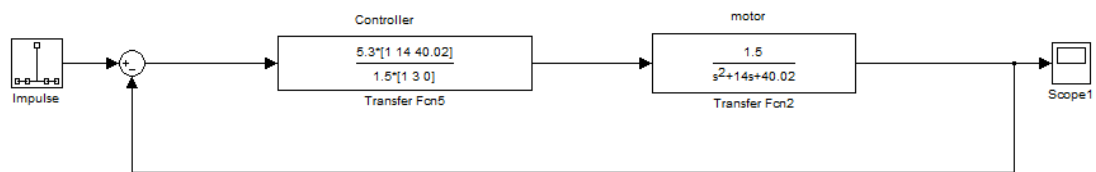


Figure (3.3):  $G_{sc}(s)$  Closed Loop

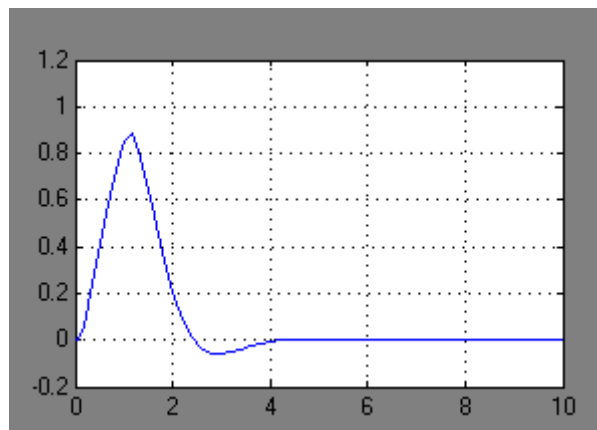


**Figure (3.4):  $G_{sc}(s)$  Closed Loop response**

Then after applying the controller  $G_c(s) = G_p(s)^{-1} \cdot G_{sc}(s)$  on the system as shown below we will get the same response because the controller cancel the behavior of the process and remain the response of the controller alone. Therefore, I can achieve the ideal desired response with systems that can be completely inverted and relatively with other systems.



**Figure (3.5): Overall closed Loop system**



**Figure (3.6): Overall closed Loop system response**



### 3.4. Robustness of Modified IMC

As we mentioned before the new structure of IMC depends on the model process to be inverted, and this model can be obtained by many ways and surely the results will be different and the uncertainty appears.

The uncertainty of the system can enclose it only in the model process and how much it differs from the real process. In other words, the parameters of the model process can take many values and this can affect the final response of the system.

Our design here will be checked for robustness by the same way mentioned in Chapter 2 that is sensitivity and complementary sensitivity function.

Reference to section 2.4, the sensitivity function and its complementary of the system shown in Figure 3.1 is

$$\varepsilon(s) = \frac{Y(s)}{d(s)} = \frac{1}{1 + G_c(s)G_p(s)} \quad (3.11)$$

$$\eta(s) = \frac{G_c(s)G_p(s)}{1 + G_c(s)G_p(s)} \quad (3.12)$$

As shown, the two functions are not linear as concluded for the old structure of IMC because the new approach is dealt as a traditional control structure and this makes it more difficult to shape these function to control performance and robustness yielding a more complex framework for robustness control problem.

### 3.5. Modified IMC for Time Delayed Systems

#### 3.5.1. Introduction

For systems with time delay, modified IMC controller will not face any problem because the design of the controller is independent on the time delay value as noted in section 2.6. In other words the controller structure is the same as time delay is varied because the time delay part is not invertible and will not be included in the design.

The behavior of this type of controllers will be tested in the following example.

This example has the same transfer function of DC motor used before but a time delay component will be added such that:

$$G(s) = \frac{1.5}{S^2 + 14S + 40.02} e^{-ts} \quad (3.13)$$

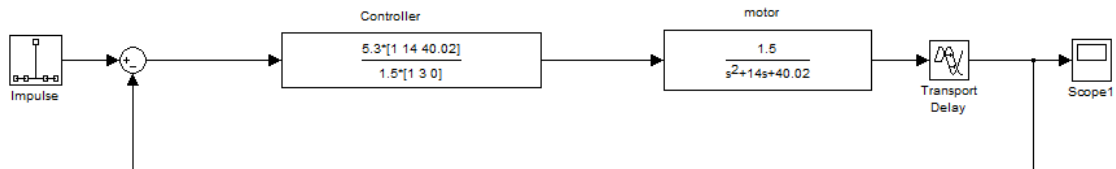
Where  $t$  is some delay time.

Then we want to achieve  $OS\% < 10\%$  and  $T_s < 5$  sec, so at first we want to design  $Y(s)$  to meet the desired such that :

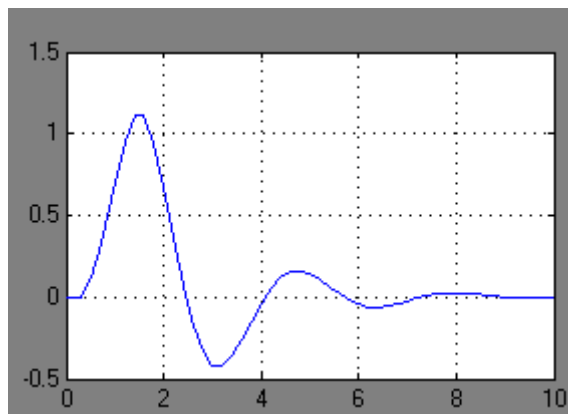
$$\frac{Y(s)}{R(s)} = \frac{5.3}{(s^2 + 3s + 5.3)} \quad (3.14)$$

Then obtain  $G_{sc}(s)$  from  $Y(s)$  such that  $R(s)$  is impulse input

$$G_{sc}(s) = \frac{5.3}{s(s+3)} \quad (3.15)$$



**Figure (3.7): The system with time delay**



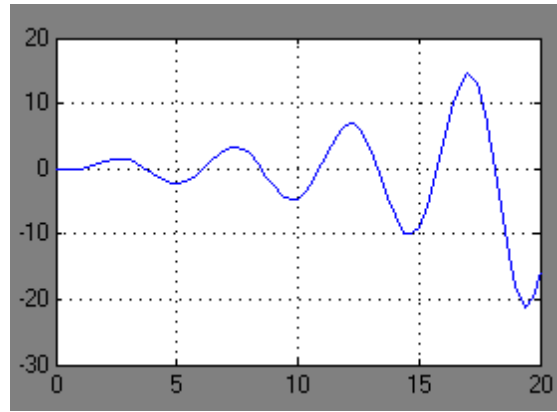
**Figure (3.8): The Impulse Response for  $t = 0.3$  sec**

Figure 3.7 shows the overall system with controller and time delay and the impulse response in Figure 3.8. We assume  $t = 0.3$  sec.

The result of simulation tells us that the time delay affect the response of the system by shifting it as the value of time delay. In addition, the response changed if we compared it with the ideal one in Figure 3.6 such that more overshoot and longer settling time.

This result can guide us to a conclusion in which if the time delay is very long the system will be unstable and the response will be unbounded as illustrated in Figure 3.9 for  $t = 1$  sec.

This implies that this type of controllers cannot compensate systems with long time delay.



**Figure (3.9): The Impulse Response for t = 1 sec**

So it is difficult to obtain satisfactory performance of control systems with time delay, which is a well recognized problem in many control processes. The solution of this problem represented by smith predictor.

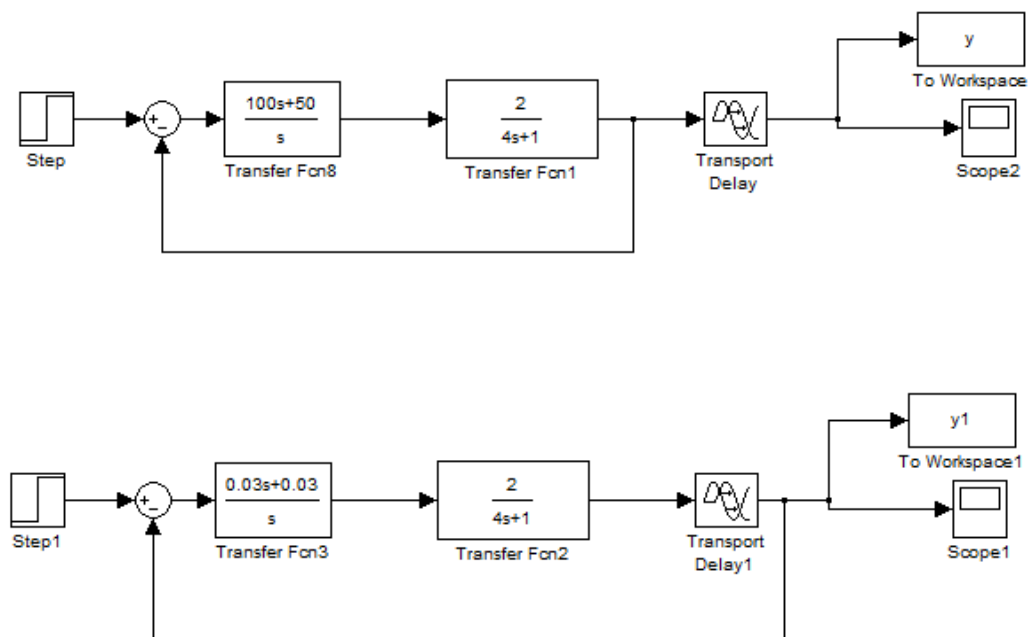
As known before the smith predictor compensate the time delay in the systems then we can deal them as a delay free systems.

### 3.5.2. Numerical Example

Assuming that the model of a system is :

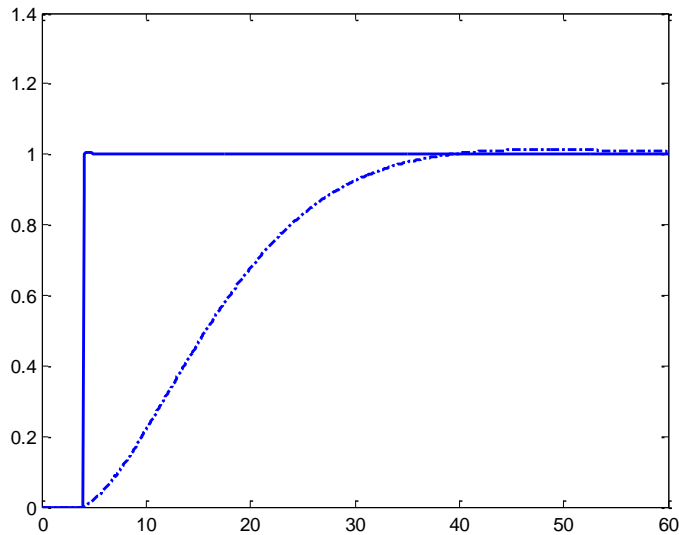
$$\frac{Y(s)}{R(s)} = \frac{2}{4s + 1} e^{-4s} \quad (3.16)$$

The system with and without smith predictor are compared in Figure 3.10.



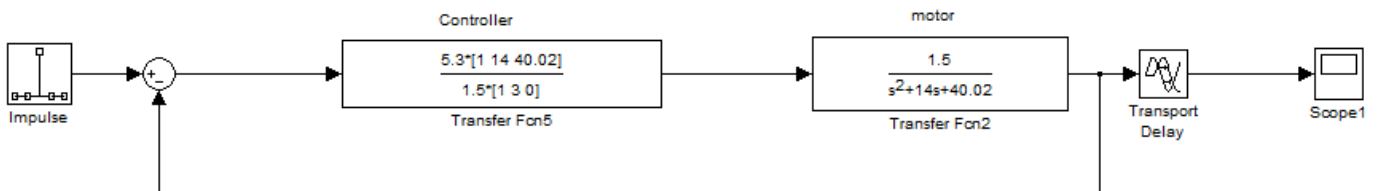
**Figure (3.10): Upper with smith predictor, Lower without smith predictor**

Parameters of the controllers are selected to get the best results, which are shown, in Figure 3.11. We can see the step response of the smith predictor is much better which has a very short settling time of 0.1 sec compared with 31 sec with a very small overshoot for both.

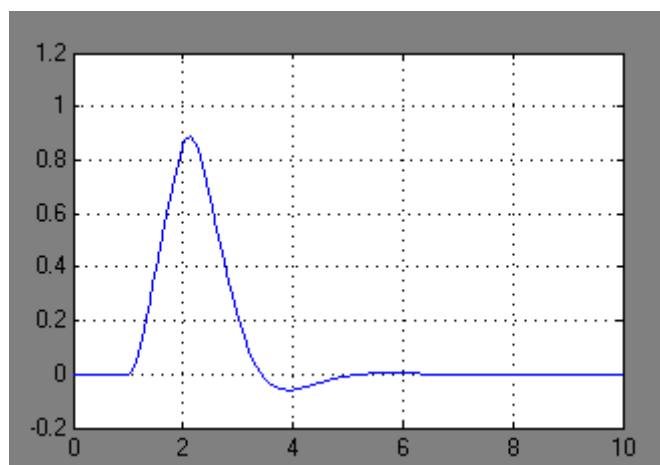


**Figure (3.11): Results of the systems, dotted without SP, solid with SP**

To be more emphasis, consider the system in equation 3.13 the system with smith predictor is shown in Figure 3.12 and its response in Figure 3.13 which approve again the same conclusion.



**Figure (3.12): The system of DC motor with smith predictor**



**Figure (3.13): Result of DC motor system with smith predictor**

### 3.6. Modified IMC for unstable systems

The general rule that section 2.8 based on is that the system to be controlled must be stable to apply the IMC controller and if the system is unstable, it should be stabilized before IMC controller is applied by any proportional controller or any other controllers. This rule here is considered as a necessary condition to apply the modified IMC controller. Therefore, in all cases, we need two controllers to handle unstable systems. Another way to deal with unstable systems is to modify the controller design in equation 3.1 such that  $G_{sc}(s)$  has another form that make the system stable and achieve the specifications.

To get the proof consider the first order unstable system process with time delay of the form:

$$G_p(s) = \frac{k}{\tau s - 1} e^{-\theta s} \quad (3.17)$$

Then we choose a proportional controller  $K$  to stabilize this system as in Figure 2.11.  $K$  is intended to stabilize the delay free unstable model  $\frac{k}{\tau s - 1}$ , this simple proportional gain  $K$  will give a stable internal process

$$G_{ps}(s) = \frac{k}{\tau s - 1 + kK} \quad (3.18)$$

Clearly,  $G_{ps}(s)$  is stable if  $K > \frac{1}{k}$ , then we can choose  $K = \frac{2}{k}$  to make

$$G_{ps}(s) = \frac{k}{\tau s + 1} \quad (3.19)$$

Then the delayed form will be

$$G_{ps}(s) = \frac{k}{\tau s + 1} e^{-\theta s} \quad (3.20)$$

that is discussed in section 2.6 in details. In addition, section 3.5 support the concept of designing the IMC controller is independent on the time delay especially for small time delays and for strong solution a smith predictor is recommended and the procedures of the two ways will be applied.

Another way can be discussed here touch the concept of our proposed controller more. Consider Figure 3.14 and let  $G_p(s)$  is factorized in another way such that:

$$G_p(s) = \bar{G}_{un}(s) \cdot \bar{G}_s(s) \quad (3.21)$$

Where  $\bar{G}_s(s)$  is a stable proper rational function and  $\bar{G}_{un}(s)$  is bi-proper antistable and minimum phase function.

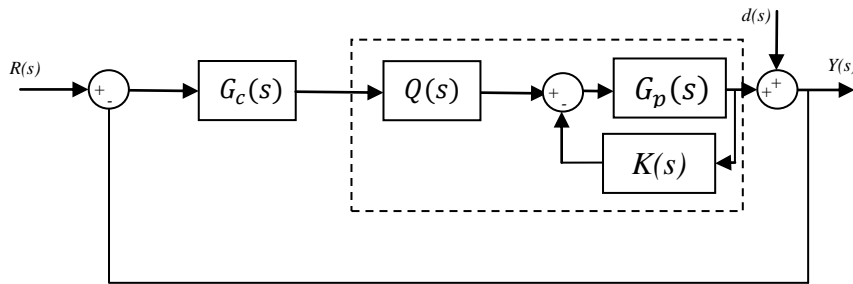
The term *antistable* refers to a system with all its poles in the open RHP and minimum phase refers to a system with all its zeros in the open LHP.

And let

$$Q(s) = \frac{1 + K(s)G_p(s)}{\bar{G}_{un}(s)} \quad (3.22)$$

Where  $K(s)$  is a stable stabilizing controller. So, the unstable poles of  $1 + K(s)G_p(s)$  is identical to that of  $G_p(s)$ . Therefore  $Q(s)$  is stable.

Then we can obtain that the dotted block is simplified to  $\bar{G}_s(s)$  which is a stable rational system and the controller  $G_c(s)$  can be designed easily as in the previous sections.



**Figure (3.14): Modified IMC for Unstable systems**

However,  $\bar{G}_s(s)$  is a stable transfer function, it will contain unstable zeros so the inversion will make a problem. So in this case another factorizing is recommended as discussed in Chapter 2 where

$$\bar{G}_s(s) = \bar{G}_{s+}(s) \cdot \bar{G}_{s-}(s) \quad (3.23)$$

and the controller then will consider the term  $\bar{G}_{s-}(s)$  in its design.

### 3.7. Summary

In this chapter, we introduced the modified IMC concept and illustrated some points for design beside its behavior against unstable systems and systems with time delay.

We can summarize the advantages of the new approach over the old one by the following points.

- The new approach groups the properties of the tradition control problem and the general IMC structure and state that there is no need for the repeated reference model and we can get the control by the same concepts and design procedures.
- Because of the presence of a model block in the traditional structure, it will consume more hardware of any type opamps or embedded to realize it. So

the operation of canceling the repeated block in the new structure reduces the hardware realization of the system controller and then cost.

- This approach goes far from the model mismatch problem that can be appeared in the traditional one since an approximated model will be used in all cases.
- Sometimes, can stabilize and get the specification in dealing with unstable system in one-step instead of two by using a controller in cascade with the IMC one.
- It can deal with time-delayed systems by using the smith predictor to compensate the delay time even if it is long.

In the other side, some points listed below talk about the disadvantages.

- The new approach sensitivity and its complementary functions are not linear such that shaping the robustness and performance will not be easy.
- Dealing with long time delay may guide us to use smith predictor.
- System must be stable to apply the controller.

## CHAPTER 4 SIMULATION AND RESULTS

### 4.1. Introduction

The inverted pendulum is a classic problem in dynamics and control theory and is widely used as a benchmark for testing control algorithms (PID controllers, neural networks, fuzzy control, genetic algorithms, etc.).

There are many aspects and models of pendulum system, but in this thesis, the model available in the electrical engineering labs shown in Figure 4.1. This model is a pendulum model system from *Bytronic Company*.



**Figure (4.1): Pendulum System**

The pendulum control system consists of a carriage module and control module. The carriage module features a pivoted rod and weight driven along 500mm (19-inch) track by a dc servomotor with integral tachometer. The carriage position and attitude of the rod/weight assembly are measured by potentiometers [26].

The position of the pendulum bob,  $y$ , the position of the carriage,  $x$ , and the angle of the pendulum,  $\theta$ , are related by the equation:

$$y = x + L \sin \theta \quad (4.1)$$

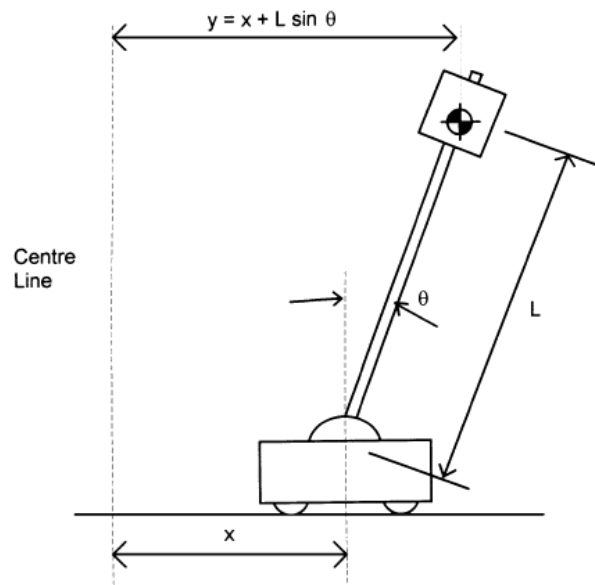
where  $L$  is the effective length of the pendulum, the distance between the pivot and the centre of mass of the combined pendulum and bob.

This tells us that in any mode, the dynamics of the position of the pendulum bob,  $y$ , is a combination of linear dynamics,  $x$ , and oscillatory dynamics,  $L \sin \theta$ .

Linear and oscillatory quantities possess quite different dynamic properties. Linear behavior with error reduction requires feedback. In feedback, oscillatory behavior will



either be amplified or damped. To analyze this response needs a frequency response test. As such the pendulum is a very difficult control problem.



**Figure (4.2): Determination of Mass Position**

## 4.2. Two modes: swinging crane and inverted pendulum

The pendulum provides two control problems: inverted pendulum (upright, base on ground), and swinging crane (turned over, pendulum hanging). The stable behavior of the pendulum in the two cases is fundamentally different. Consider the two variables  $x$  and  $\theta$ . In the case of the inverted crane  $x$  and  $\theta$  can be varied independently and the crane is still stable: move  $x$ ,  $\theta$  will return to zero, change  $\theta$ ,  $x$  will not be affected.

By contrast, with the pendulum inverted and stable, any small change  $\Delta\theta$  in  $\theta$  requires an adjustment  $\Delta x$  in  $x$ , as  $x$  has to be adjusted to keep the pendulum upright. Variations in  $x$  are dependent on  $\theta$ . However, the reverse is also true, variations in  $\theta$  are dependent entirely on  $x$ . Any adjustment  $\Delta x$  in  $x$  requires a small change  $\Delta\theta$  in  $\theta$ . This means that for the inverted pendulum it is not meaningful to talk about  $x$  and  $\theta$  as independent variables.

This has the consequence that the description and dimension of the control problem of the pendulum are different in the two modes. In the crane mode  $x$  and  $\theta$  are independent variables and so the position of the pendulum is described by  $(x, \theta)$ . This is two-dimensional, by contrast in the inverted pendulum mode  $x$  and  $\theta$  are not independent variables. Any attempt to balance the inverted pendulum in terms of  $x$  and will have to take into account all the modes of interaction between  $x$  and  $\theta$  as well as the values of  $x$  and  $\theta$  themselves. However, we only consider the stable control problem. So long as the pendulum is in balance, we can talk about a single independent variable, the position of the pendulum bob or  $y$ . Thus, the appropriate variable for control for the inverted pendulum is  $y$  alone. This is one-dimensional.

### 4.3. Calculation and instability of $y$ for inverted pendulum

We shall now consider the inverted pendulum mode alone for a moment. In the inverted pendulum mode, so long as the pendulum is balanced, the behavior of  $\theta$  is small angle ( $\theta$  smaller than about  $15^\circ$  or so) and we can apply the "small angle" approximation:

$$\sin \theta \approx \theta \quad (4.2)$$

(with  $\theta$  measured in radians). Substituting into equation 4.1 we obtain:

$$y = x + L \theta \quad (4.3)$$

As  $L$  is fixed in any one control application, this means we can quickly calculate  $y$  in terms of  $x$  and  $\theta$ , which are measurable. Hardware analogue control requires that this calculation is performed in analogue terms, and in fact, the Control Module performs this calculation in analogue voltages. If  $V_x$  is a voltage representing  $x$ , and  $V_\theta$  a voltage representing  $\theta$ , then  $V_\theta$  can be scaled by a factor  $a$  (using an op-amp with a variable resistor to change the multiplication factor) and then summed with  $V_x$  using a summing junction to give a voltage  $V_y$  representing  $y$  on the same scale as  $V_x$ .

Thus,

$$V_y = V_x + aV_\theta \quad (4.4)$$

a voltage implementation of equation 4.4, with the factor  $a$  scaled to represent the value of  $L$ . This is the method used to give the voltage representing  $y$  which is available from junction  $L$  on the Control Module. Note that though this voltage sum is exact, the value  $V_y$  is an approximated representation of  $y$ , because equation (4.2) is an approximation.

### 4.4. Dynamic Model of the Pendulum

In this part, we will model the dynamic behavior of the pendulum. We shall do this by observing the transient response of the system from an initial value. Before fitting the pendulum rod into the carriage, position the mass at the end of the rod. Estimate the position of the centre of mass of the rod/mass assembly by trying to balance it on your finger. (The centre of mass is located just below the bottom of the mass). We shall call this length the effective pendulum length  $L$ . Screw the pendulum rod firmly into the carriage. Tip the rig upside down into the "crane" position. Connect the pendulum angle signal,  $V_\theta$ , to the oscilloscope and make some calculation to get the model [26].

Finally, the pendulum can be modeled approximately as a second order system:

$$G(s) = \frac{1}{1 + 0.0011s + 0.0264s^2} \quad (4.5)$$

The final system is a stable second order system relates the voltage to the angle. Then we browse the internal model control technique and theory and knew the design procedures to get robust control system. In the last chapter, the new approach is introduced and slightly compared with the general structure.

In this chapter, we will apply the general structure, modified IMC controller to the pendulum system, and get the simulation results by Matlab. Many other perturbation will be added to the system to test the efficiency of controllers as adding white noise disturbance or time delay or varying the parameters of the system.

The main objective is to design an IMC controller for the proposed pendulum system by the traditional and the new approach that:

1. Can regulate the angle of the pendulum rod regardless of the cart position.
2. Satisfying the response specification.
3. Reduce the effect of disturbance due to mismatching in modeling.
4. Achieve the robustness of the controlled system.

The control problem of pendulum system is considered as a regulation problem in which the input to the system is zero and the only forces affected the system are the initial conditions or the disturbances. Because we deal with transfer functions then the initial conditions are equal zero and the simulation restricted on disturbance force only as noted in the following sections.

To fully test the controllers, the following change in plant parameter values and other external disturbance simulations were independently conducted:

1. Impulse disturbance input at the plant output.
2. Unit step disturbance at the plant output.
3. White noise disturbance at the plant output.
4. A change in the plant, due to a change in plant parameters values.
5. A change in the plant, due to a change plant time delay values.

#### **4.5. Impulse disturbance input**

A simulation of the system using this controller was firstly conducted with no plant model mismatches, and no delay and as per IMC theory, it was determined to achieve a near ideal response. The block diagram and the response of the system to a unit impulse disturbance are shown below.

Figure 4.3 exhibit the block diagram of overall system of the traditional IMC structure and note that the input is zero but there is an impulse disturbance input. There is no mismatch between the process and its transfer function model. The controller is designed according to the procedures mentioned in Chapter 2 as follows:

The base transfer function of the design is the model transfer function since it is the result of the modeling operation. Then the transfer function is :

$$\bar{G}_p(s) = \frac{1}{1 + 0.0011s + 0.0264s^2} \quad (4.6)$$

According to equation 2.39 and the rules of splitting to  $\bar{G}_{p-}(s)$  and  $\bar{G}_{p+}(s)$

$$\bar{G}_{p+}(s) = 1 \quad (4.7)$$

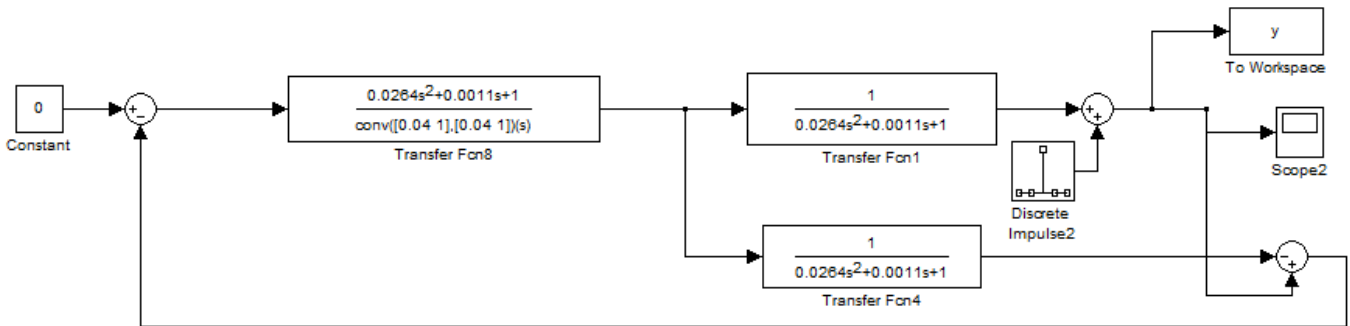
$$\bar{G}_{p-}(s) = \frac{1}{1 + 0.0011s + 0.0264s^2} \quad (4.8)$$

Then we should select a filter to obtain a proper transfer function. Therefore, we conclude that the filter should have an order of  $n=2$ . The rest of design is to determine the value of  $\lambda$  and by equation 2.50 the value of  $\lambda = 0.04$ .

$$\lambda \geq \left( \lim_{s \rightarrow \infty} \frac{D(s)N(0)}{20s^n N(s)D(0)} \right)^{\frac{1}{n}} = \left( \lim_{s \rightarrow \infty} \frac{(1 + 0.0011s + 0.0264s^2)(1)}{20s^2(1)(1)} \right)^{\frac{1}{2}} = 0.0363 \quad (4.9)$$

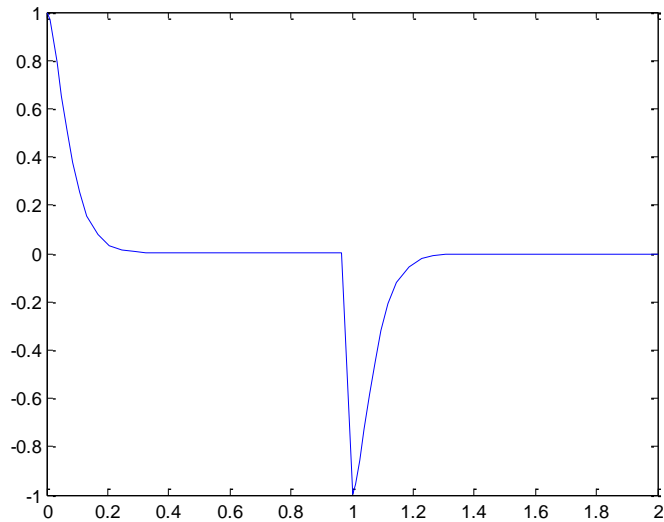
The controller transfer function will be

$$C(s) = \frac{1 + 0.0011s + 0.0264s^2}{(0.04s + 1)(0.04s + 1)} \quad (4.10)$$



**Figure (4.3): Block Diagram of the system with impulse disturbance input**

Figure 4.4 shows the impulse disturbance input response. The impulse input has a width of 1 sec to view all response time without cutting. The response of the system at 0 sec began at amplitude of 1 due to the disturbance appearance and the system behaves such that it eliminates this affect and return to zero. As the input vanishes at 1 sec the system behaves in an opposite manner also to return to zero. The response has no overshoot with settling time about 0.3 sec and no steady state error.



**Figure (4.4): Impulse disturbance input response**

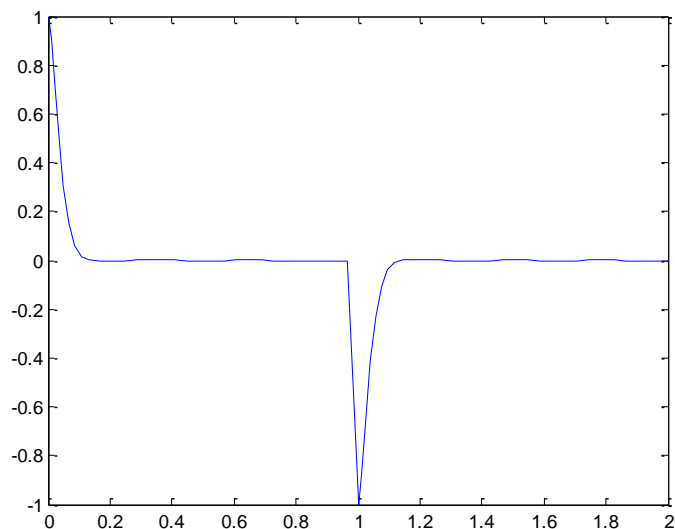
The second part is to simulate the new approach against the same conditions. The transfer function is the same but the structure and the controller will be different.

Reference to section 3.2, we must determine  $G_{sc}(s)$  such that there is no overshoot with settling time  $< 0.3$  sec, then  $G_{sc}(s)$  could take the form of

$$G_{sc}(s) = \frac{2000}{s^2 + 80s} \quad (4.11)$$

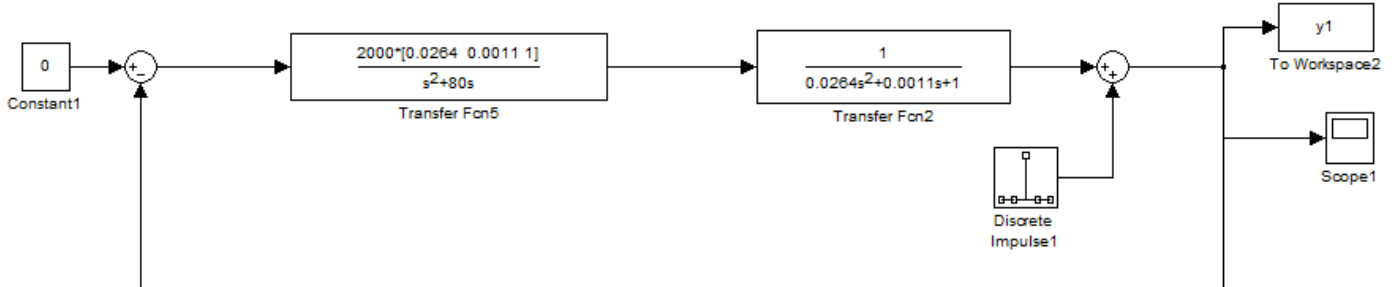
And if we examine the closed loop of  $G_{sc}(s)$  as in Figure 3.2 then we get the response shown in Figure 4.5.

It is clear that the response achieve the requirements for the same impulse disturbance input. We assume the gain of the controller is freely determined during design and here the value of 2000 is satisfactory.



**Figure (4.5): The closed loop response of  $G_{sc}(s)$**

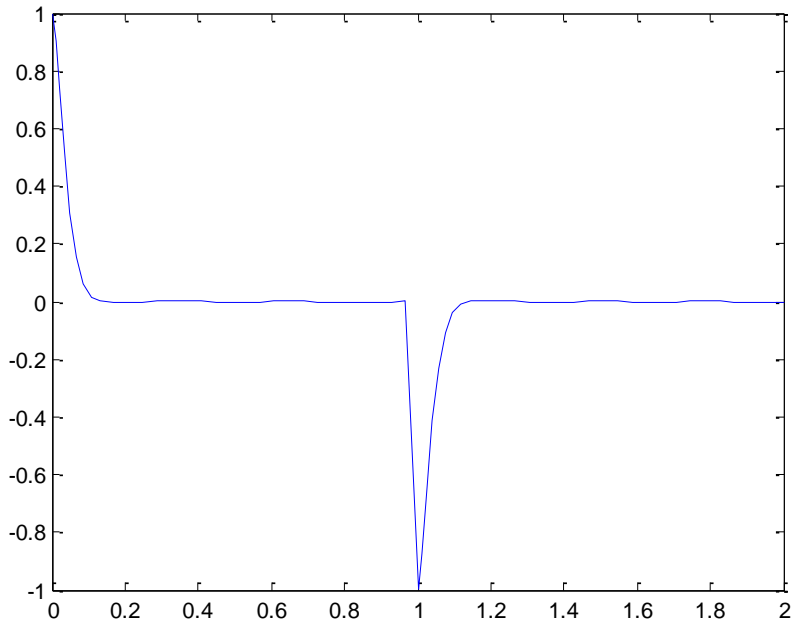
The next step is to use the form of  $G_{sc}(s)$  to be added to the system in Figure 3.1, and get the new controller system then grade the response of it. We expect, according to Chapter 3. The response of the system will be the same as Figure 4.5.



**Figure (4.6): The block diagram of the modified IMC**

The controller transfer function is:

$$C(s) = \frac{2000(1 + 0.0011s + 0.0264s^2)}{s^2 + 80s} \quad (4.12)$$



**Figure (4.7): The response of modified IMC**

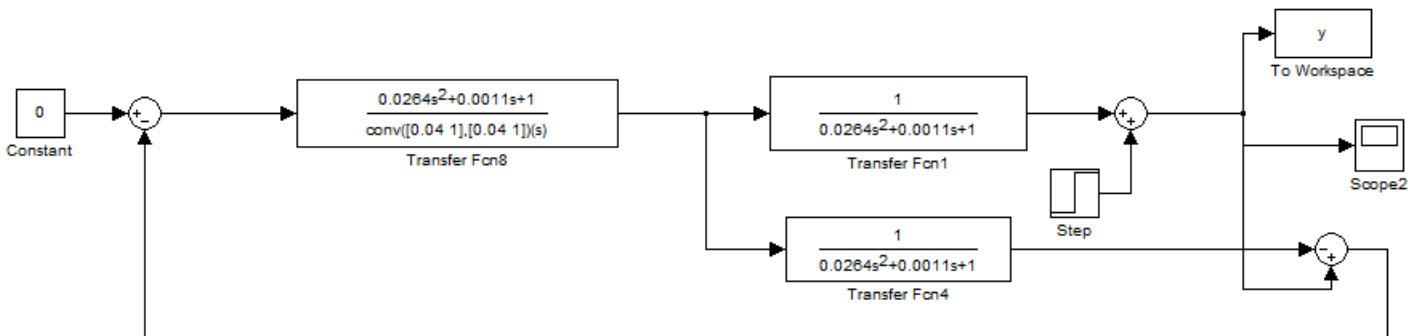
Figure 4.7 shows the modified IMC system against the disturbance and it is identical to Figure 4.5 as expected and achieve the specifications.

If we compare the responses of the two methods, we can say that the new approach is easy to design than other and can improve the response more by the gain only. Even be fair the traditional method of IMC also can improve the response by selecting another  $\lambda$ .

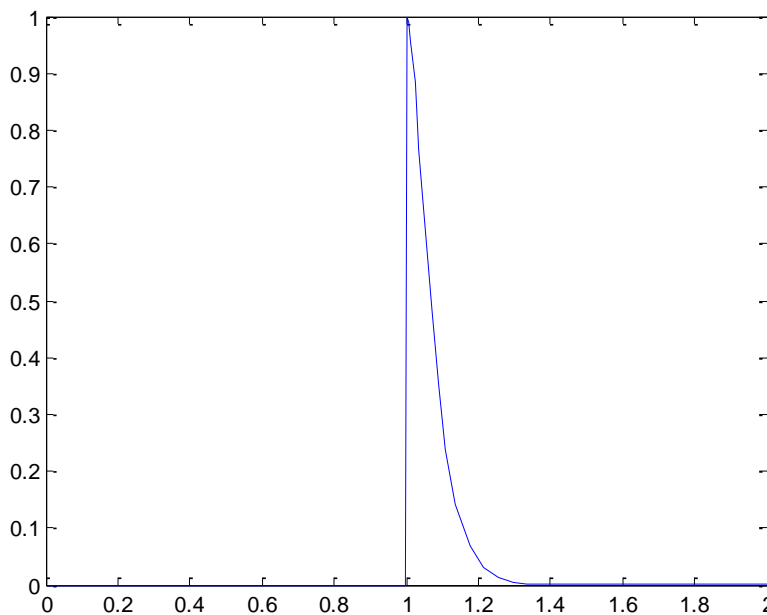
#### 4.6. Step disturbance input

This section discusses the same concepts as section 4.5 with the same controllers and procedures. As we knew, the impulse is combined from two step functions, so the responses will be the same in a part of it.

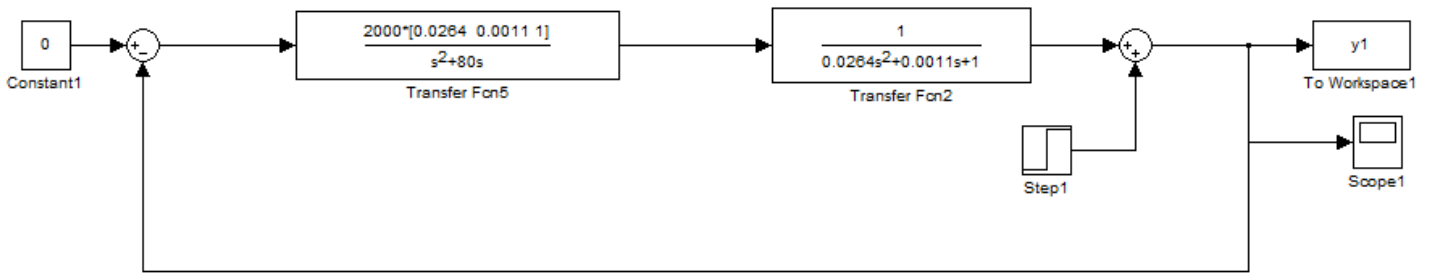
Figure 4.8 shows the system of traditional IMC with step disturbance input.



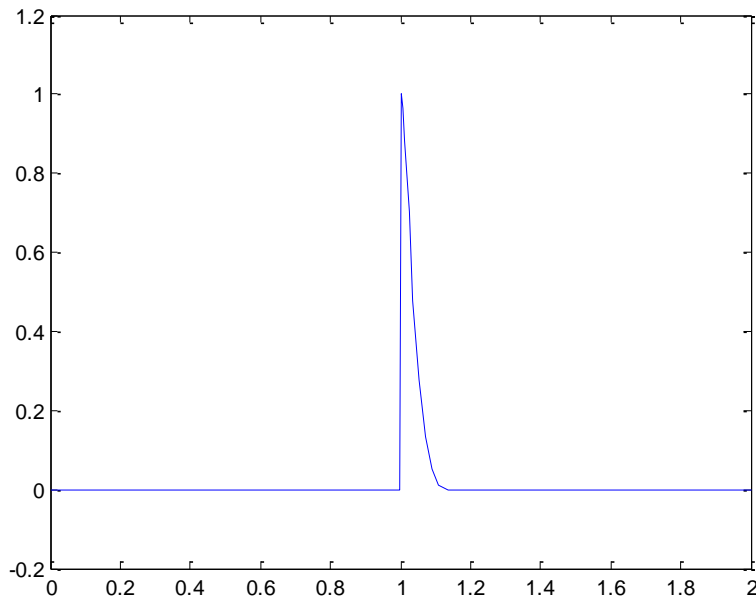
**Figure (4.8): IMC system with step disturbance input**



**Figure (4.9): Step disturbance input response at t=1sec**



**Figure (4.10): Modified IMC with step disturbance input**



**Figure (4.11): Step disturbance input response of modified IMC at t=1sec**

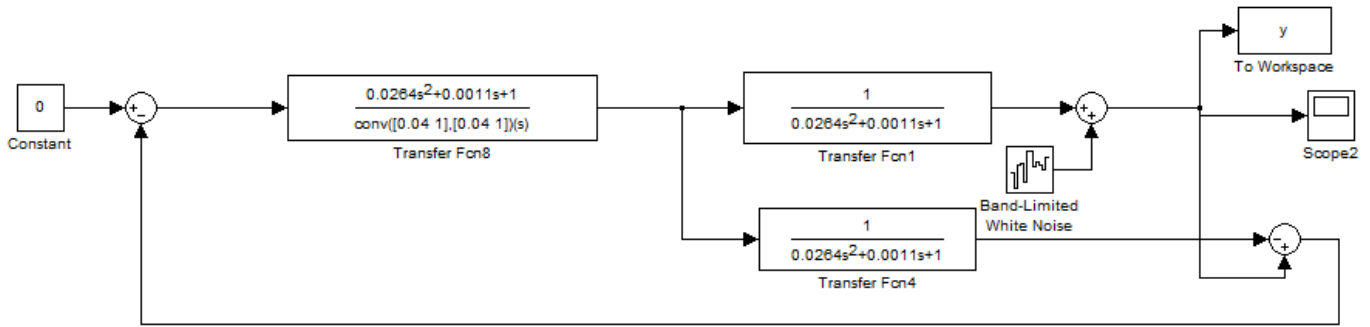
Figure 4.10 and 4.11 has the same results obtained in the previous section such that settling time by the new method is 0.1sec while by the old is 0.3 sec.

#### 4.7. Band limited white noise disturbance at the plant output

Very often the plant may suffer from random disturbances, which may not be easily identifiable, which means that a simple transfer function to model the disturbance (as was the case with the step and impulse disturbances) may not be adequate.

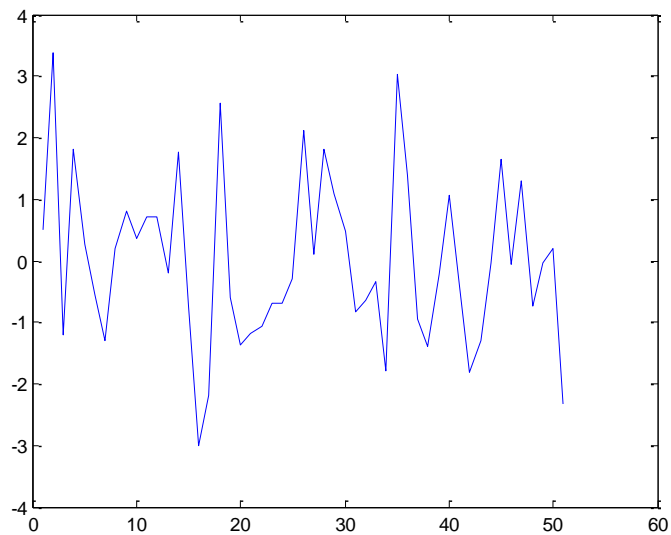
A stochastic disturbance model in the form of a band limited white noise source shall be used to simulate unknown disturbances of this kind. The output of the random disturbance subsystem is shown in Figure 4.13. It comprises a sinusoid with variable amplitude and frequency. The response of the systems is shown below, they closely follow the noise (since the disturbance was applied to the output of the plant), there was no instability, and oscillates about the correct set point of zero.



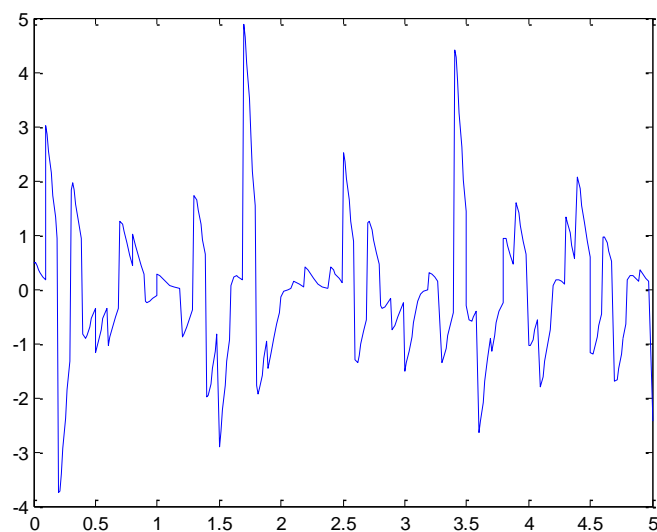


**Figure (4.12): IMC system with white noise disturbance input**

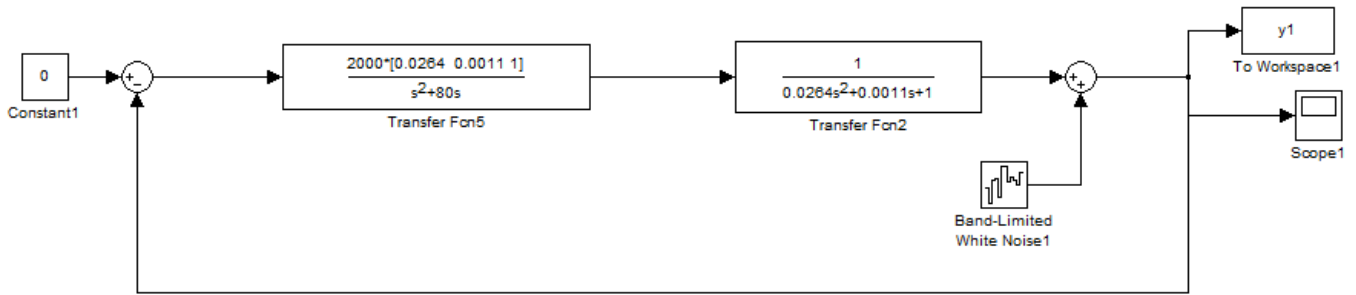
Figure 4.12 describes the IMC system with white noise disturbance input while the response of it shown in Figure 4.14, which gives an indication to what happened. The output tries to eliminate the input affects and return to its set point zero and by comparing it with the response of the modified IMC in Figure 4.16 the results say that the modified IMC is slightly better since it seems quicker and have lesser time response.



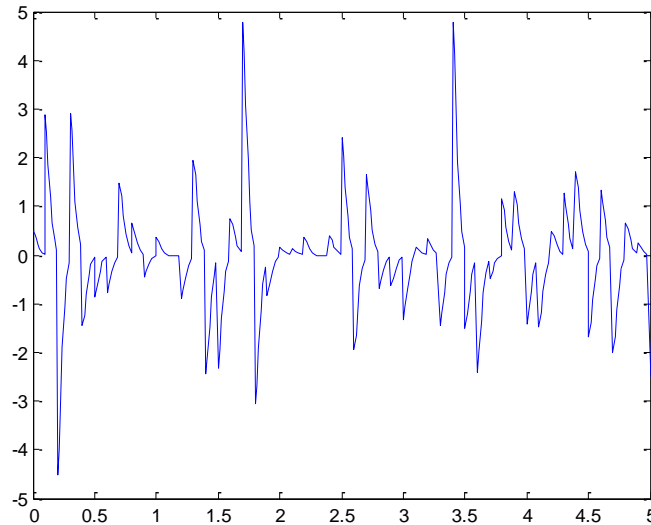
**Figure (4.13): Band limited white noise disturbance**



**Figure (4.14): Response of IMC system to WN disturbance input**



**Figure (4.15): Modified IMC with to noise disturbance input**



**Figure (4.16): Response of modified IMC system with WN disturbance input**

#### 4.8. Systems with a plant/model mismatch

As mentioned in the previous chapters, the plant/model mismatch is very common and modeling is an approximating operation that converts the physical system to some equations that describe the system. The plant/model mismatch can appear in the parameter due to measuring error or in another form as dealing with high order systems as low order ones that increase the gap between them.

Beside that, the pendulum system is a nonlinear system and the transfer function of it is a result of the linearization operation so the mismatch is present in all cases.

In this section, we will choose some parameters and vary their values in the model such that the plant and model transfer function are different. Then the controller will use the model transfer function, which suffer from mismatch, for its design and apply a step disturbance input to study the behavior of each controller.

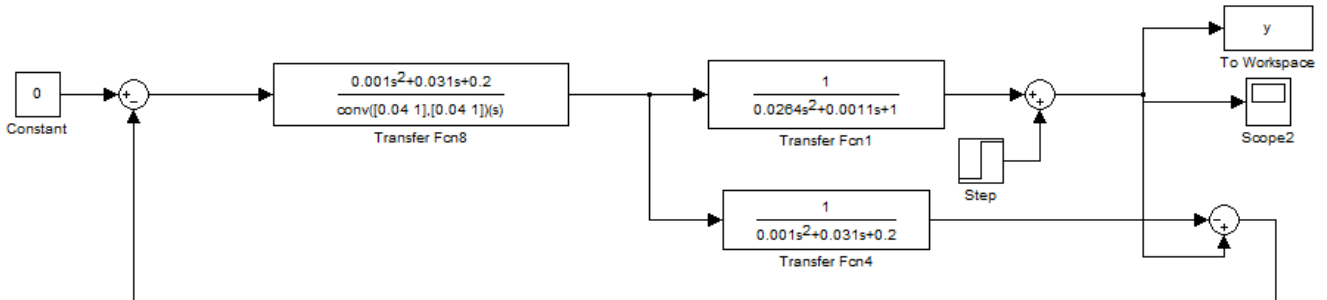
Figure 4.17 shows the mismatch of the two transfer function such that:

$$G(s) = \frac{1}{1 + 0.0011s + 0.0264s^2} \quad (4.13)$$

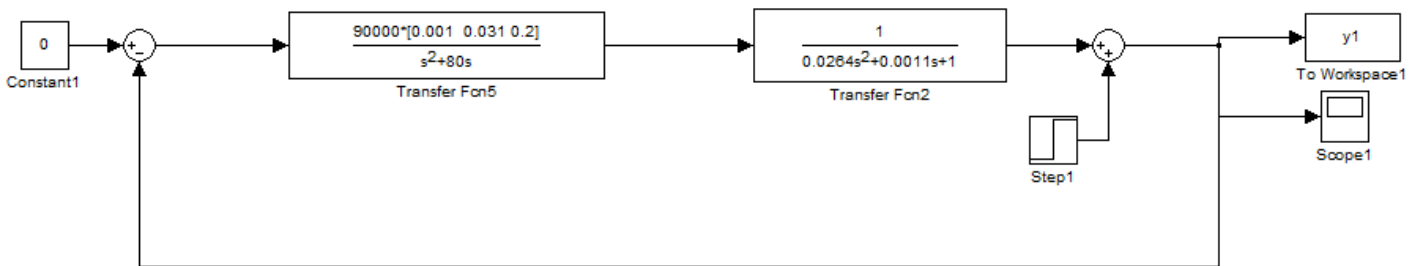
$$\bar{G}_p(s) = \frac{1}{0.2 + 0.031s + 0.001s^2} \quad (4.14)$$

Then the controller of IMC takes the form

$$C(s) = \frac{0.2 + 0.031s + 0.001s^2}{(0.04s + 1)(0.04s + 1)} \quad (4.15)$$



**Figure (4.17): A plant/model mismatch of IMC system**



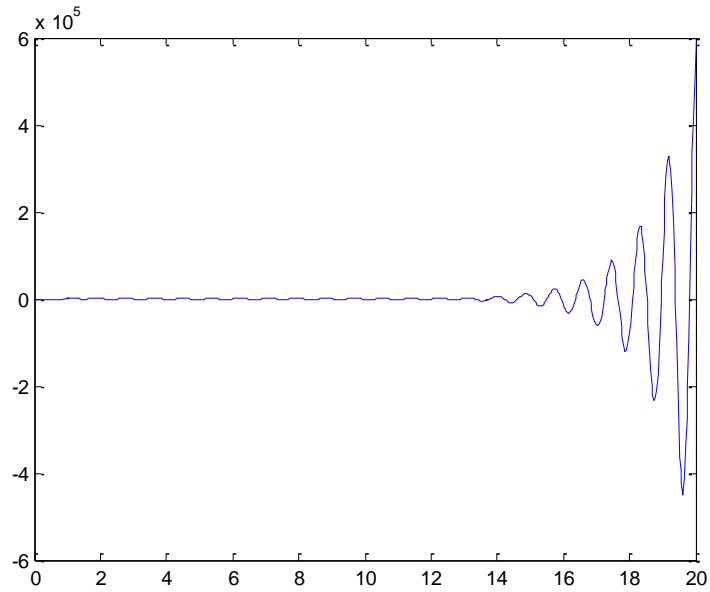
**Figure (4.18): A plant/model mismatch of modified IMC system**

The controller of modified IMC takes the form

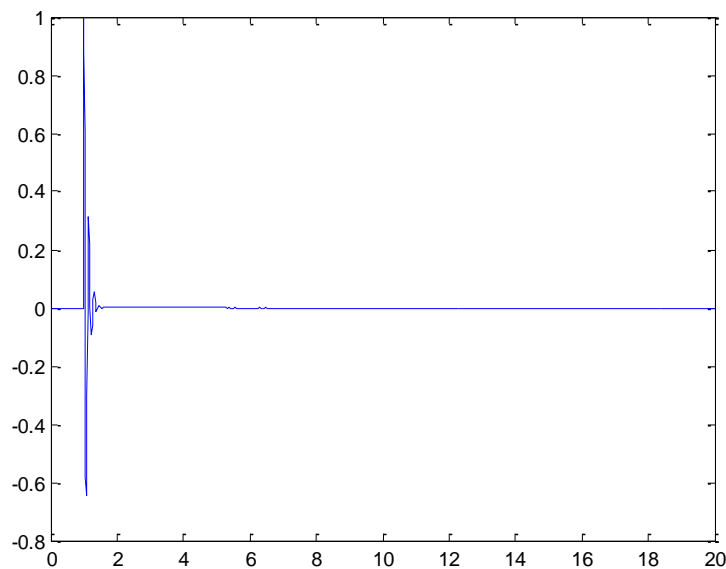
$$C(s) = \frac{90000(0.2 + 0.031s + 0.001s^2)}{s^2 + 80s} \quad (4.16)$$

The responses of the two techniques are displayed in Figure 4.19 and 4.20. The results are very clear to say that the modified IMC structure is now the best and overcome the mismatch and regulate its output to be zero against the traditional IMC structure, which behaves unstable, and the controller fails to regulate the output.

This small comparison worked to tip the modified IMC despite of the disadvantage of using some high gain in the controller. However, it guarantees the stability and regulation.



**Figure (4.19): Response of IMC due to plant/model mismatch**



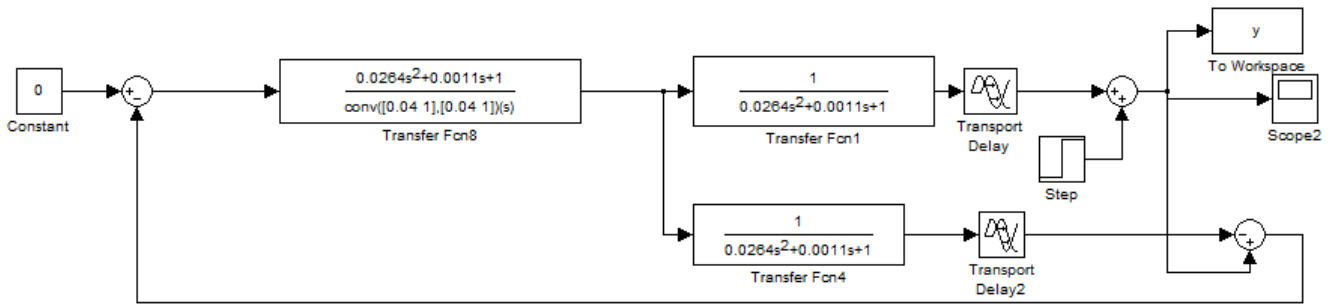
**Figure (4.20): Response of modified IMC due to plant/model mismatch**

#### 4.9. System with time delay

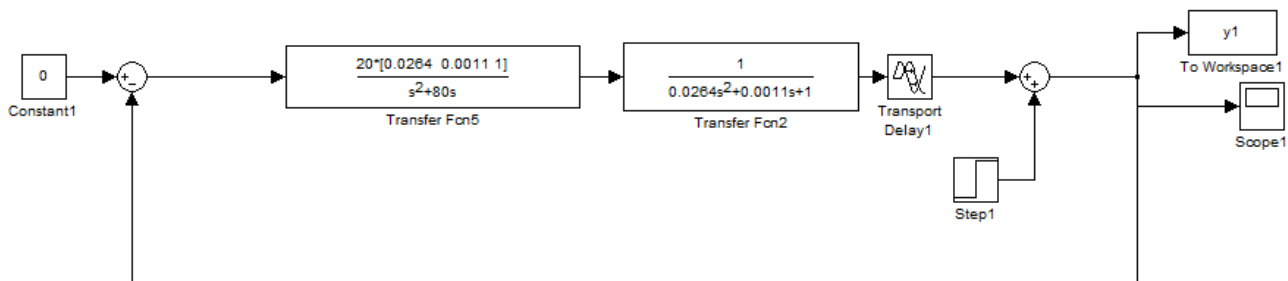
The system seems that does not have time delay, but in many cases there is a time delay in almost all systems due to physical components characteristics and storage elements in the system although it might be very small.

Based on this, we assume there is a small time delay in the pendulum system beside a mismatch in this delay between the plant and the model to make the competition worth.

The controller for two cases are identical to section 4.5 because the time delay is considered as a non minimum phase term and does not affect the design.



**Figure (4.21): IMC structure with time delay mismatch**



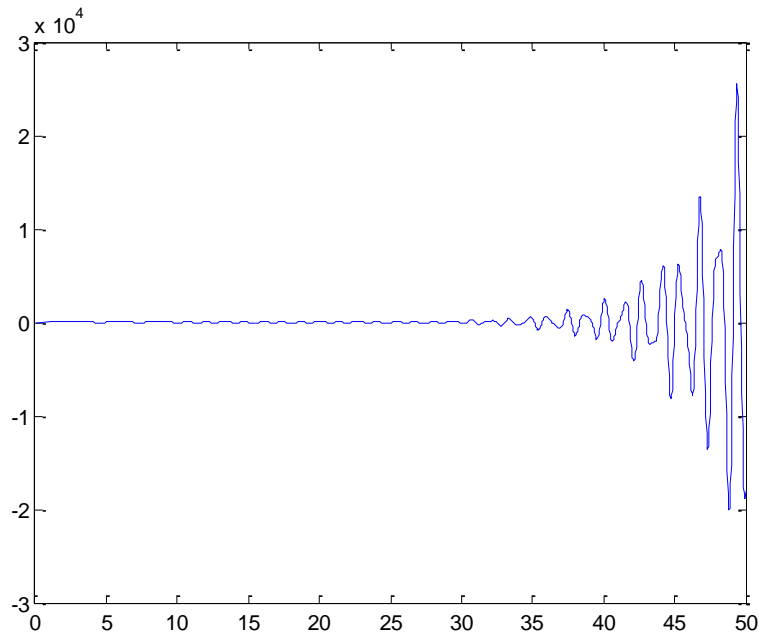
**Figure (4.22): Modified IMC structure with time delay**

In Figure 4.21 the system has a time delay for the plant  $t = 2$  sec while its model has  $t=2.5$  sec. Figure 4.22 has also  $t=2$  sec delay for its system.

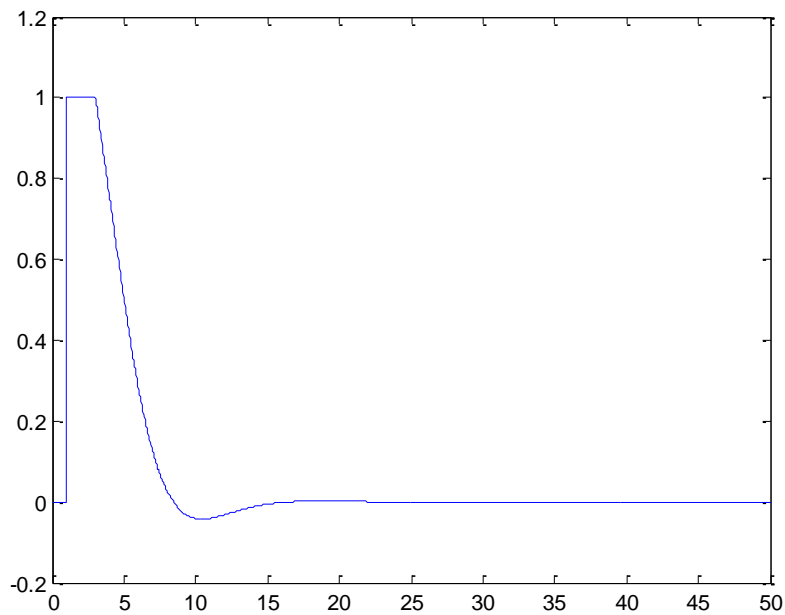
The time response of each system are shown in Figures 4.23 and 4.24 and the responses again worked to tip the modified IMC since it regulate the output and overcome the perturbation results in modeling and save the stability. In the other hand, the traditional IMC lose the control and the response unbounded to finally yield to instability. The disadvantage of the modified IMC takes more time response and gets stability but this is forgiven when we compare with the traditional one.

#### 4.10. Comparison with previous work

According to [27], the paper compared the performance of the PID controller against IMC controller and the results indicate that the proposed IMC controller provides fast and smooth set-point response without a loss of disturbance performance.



**Figure (4.23): Response of IMC with a mismatch time-delayed system**

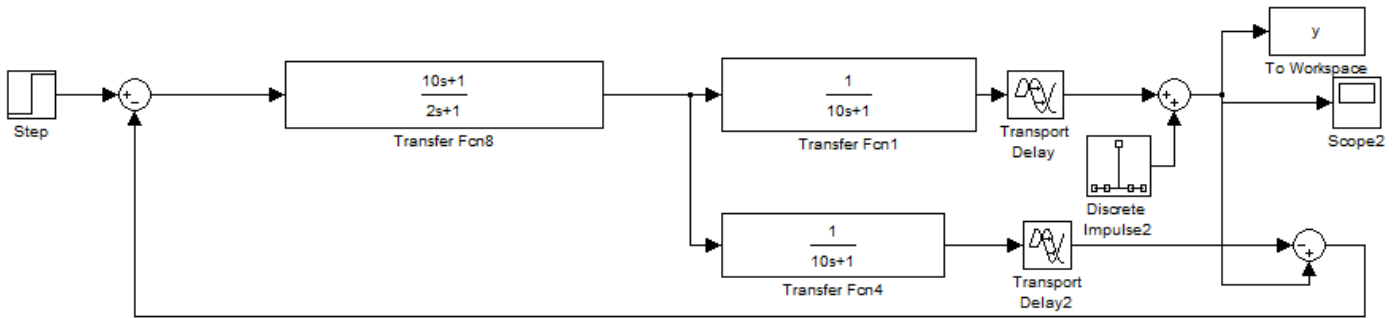


**Figure (4.24): Response of a modified IMC time-delayed system**

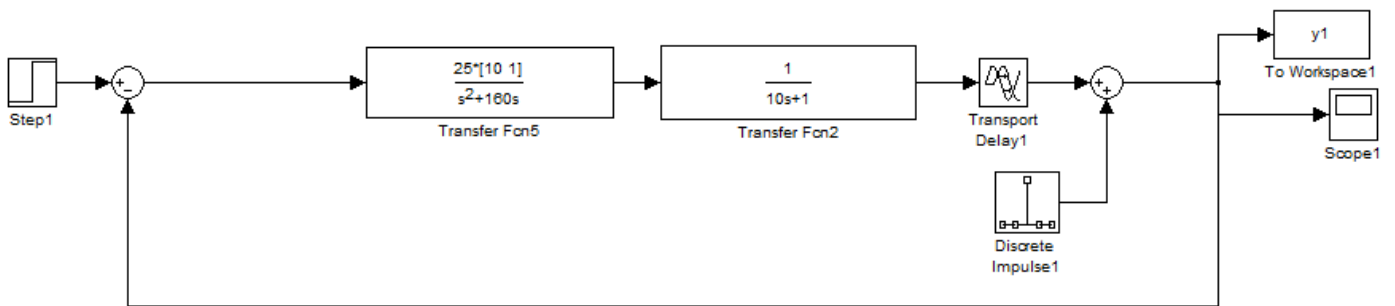
In the same way, this section compares the results of the preceding results with the new approach result when applying it to the same system.

The transfer function of the system is:

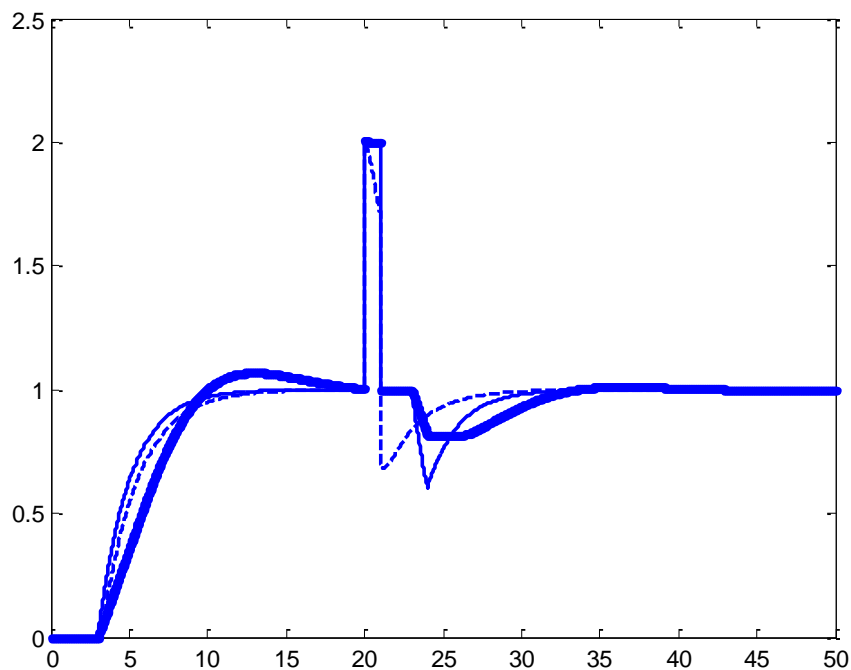
$$G(s) = \frac{1e^{-3s}}{1 + 10s} \quad (4.17)$$



**Figure (4.25): IMC structure of the proposed system**



**Figure (4.26): Modified IMC structure of the proposed system**



**Figure (4.27): Response of both controllers to the proposed system**

Figures 4.25 and 4.26 exhibit the structure of both methods and the results are shown in Figure 4.27. The solid line indicates the traditional IMC, the bold line for modified IMC without smith predictor, the dotted line for modified IMC with smith predictor.

Simulation results indicate that the response of the modified IMC with SP is superior which compensate the time delay. The modified without SP has a small overshoot but it needs little effort to eliminate disturbance.

The traditional IMC suffer from a delay of 3 sec to compensate the disturbance and overshoot 50%. On the other side, the new method without SP has an overshoot of 20% but with SP it is 40% but without any delay.



## CHAPTER 5 CONCLUSION

The internal model control (IMC) philosophy relies on the internal model principle, which states that control can be achieved only if the control system encapsulates, either implicitly or explicitly, some representation of the process to be controlled. In particular, if the control scheme has been developed based on an exact model of the process, then perfect control is theoretically possible.

A new approach of control design of internal model controller was proposed in this thesis. The proposed design method focused on modifying the old general structure of IMC and got a new one with saving the same general concept of using the invertible version of the system in the controller design. The new approach combines the IMC structure and the traditional structure of a control problem and this demonstrate an excellent performance and behavior against different disturbance inputs and model uncertainty presented in model mismatch.

The research browsed the pendulum system and got its transfer function to be the base of the design, which examined our proposed controller, and then an overview about IMC was listed. Furthermore, it went in detail about the theory of IMC and the revolution of its structure beside the limitations and obstacles that prevent the perfect control and illustrated the design procedures to get the best response without going unstable.

The new method explained and raised the advantages and disadvantages against the traditional one. In addition, a new design procedure was proposed to deal with unstable systems and time delayed systems by the support of smith predictor.

The results are approved the robustness of the new method and get a graded responses when compared with others.

A comparison between the IMC and new IMC was conducted and shows that the new IMC is superior to old one.

In this thesis, we considered the transfer function of the rod of the pendulum that related the angle as an output to the input, it can be expanded to the entire system including the position and apply the same approach to study the behavior. Another idea is concerning on treating with the pendulum system as a nonlinear system and propose a controller to deal with its nonlinearity.

In addition, may be realization with opamps or embedded system is needed to implement the controller. Then the concept will expand to handle the discrete version of IMC technique.

## References

- [1] Garcia, C. E. and Morari, M., “*Internal Model Control - Unifying Review and Some New Results*”, Industrial Engineering Chemical Process Design and Development, vol. 21,1982.
- [2] Bahram, S. & Hassul, M., *Control System Design*, Prentice-Hall, NJ, 1993.
- [3] Scott A. Geddes ,Thesis, “*Internal Model Control (IMC) of a Fruit Drying System*”, University of Southern Queensland,2006.
- [4] Jiliang Shang, Guangguang Wang, “*Application Study on Internal Model Control in Boiler Burning System*”, 2010.
- [5] Caifen Fu, Wen Tan, “*Active control of combustion instability via IMC*”, 2008.
- [6] JIN Qi-bing, FENG Chun-lei, LIU Ming-xin, “*Fuzzy IMC for Unstable Systems with Time Delay*”, IEEE Pacific-Asia Workshop on Computational Intelligence and Industrial Application, 2008.
- [7] Wen Tan, Horacio J. Marquez, Tongwen Chen, “*IMC design for unstable processes with time delays*”,2003, accessed on: April 2011, Online:  
[http://dsp.vscht.cz/konference\\_matlab/MATLAB09/prispevky/035\\_hanta.pdf](http://dsp.vscht.cz/konference_matlab/MATLAB09/prispevky/035_hanta.pdf) .
- [8] Kou Yamada, “*Modified Internal Model Control for unstable systems*”, Proceedings of the 7th Mediterranean Conference on Control and Automation (MED99) Haifa, Israel - June 28-30, 1999
- [9] Smith, O. J. M., “*Closer Control of Loops with Dead Time*” Chem. Eng. Progress, 1975.
- [10] Newton, G. C., L. A. Gould, and J. F. Kaiser, “*Analytic Design of Feedback Controls*”, John Wiley & Sons, NY, 1957.
- [11] Coleman Brosilow, Babu Joseph, “*Techniques of Model-Based Control*”, 2002.
- [12] Agachi, Nagy, Cresti and Lucaci, “*Model Based Control*”, 2006.
- [13] Athans, “*Lecture notes on multivariable control systems*”, LIDS. M.I.T,1984.
- [14] Brosilow, “*Personal Communication*”, Case Western Reserve University, Cleveland, OH, 1983.

- [15] Daniel Rivera, Manfred Morari and Sigurd Skogestad, “*Internal Model Control*”, 1986.
- [16] Ricardo S. Sanchez-Pena, & Mario Sznajder, “*Robust Systems Theory and Applications*”, John Wiley & Sons, Inc., Canada, 1998.
- [17] Muing, T Tham, “*Internal Model Control (Introduction to Robust Control)*”, accessed on: March 2011, Online: <http://lorien.ncl.ac.uk/ming/robust/sensfunc.pdf> , 2002.
- [18] Holt, B. R., Morari, M. Chem. Eng. Sci. in press, 1985.
- [19] Brosilow, C.B., “*The structure and design of Smith predictors from the viewpoint of inferential control*”, 1979.
- [20] P. B. Deshpande and R. H. Ash, “*Elements of Computer Process Control With Advanced Control Applications*”. Research Triangle Park NC: Instrument Society of America, 1981. pp. 227-250.
- [21] O. J. M. Smith, “*Closer control of loops with dead time*” ,Chemical Engineering Progress. vol. 53(5). pp. 217-219, 1957.
- [22] J. E. Marshall. “*Control of Time-Delay Systems*”, Stevenage United Kingdom: Peter Peregrinus Ltd.. 1979.
- [23] A. T. Bahill and J . D. McDonald. “*The smooth pursuit eye movement system uses an adaptive controller to track predictable targets*” ,in *Proc Int Conf Cxbern Soc.* NewYork: IEEE, 1981. pp. 269-278.
- [24] A. Terry Bahill, “*A Simple Adaptive Smith-Predictor for Controlling Time-Delay Systems*”, IEEE Control Systems Magazine, 1983.
- [25] I. L. Chien and Fruehauf, “*Consider IMC tuning to improve controller performance*”, Chem. Eng. Prog., Vol. 86, No. 10, pp. 33, 1990.
- [26] Byronic company, “*Pendulum system model manual*”, 2001, accessed on: April 2011, Online: [http://www.lehigh.edu/~inconsy/lab/experiments/PCS\\_Manual.pdf](http://www.lehigh.edu/~inconsy/lab/experiments/PCS_Manual.pdf) .
- [27] M. Shamsuzzohal, Moonyong Lee, “*IMC Based Control System Design of PID Cascaded Filter*”, SICE-ICASE International Joint Conference, 2006.